



GERARD INSTALLATION MANUAL

 **GERARD**
The worry-proof roof

INTRODUCTION

WELCOME TO THE GERARD® ROOFS' EXPERIENCE

This comprehensive installation manual has been designed to assist with all aspects of installing Gerard® roofs. Following this step by step installation guide will result in a professional and aesthetically pleasing roof installation that will complement any home for many years to come.

It should be emphasised, however, that this Installation Manual is for guidance only. It is the responsibility of the installer to ensure that all National Standards and Local Building Regulations are strictly adhered to and they must take precedence over the installation techniques recommended in this manual.

We have covered most eventualities in this guide. Should you need to contact us for further assistance or for help in determining the minimum local building standards, please see our office details on the back cover of this manual.

GERARD® ROOFS – TRADEMARK OF IKO METALS EUROPE

IKO Metals Europe leads the world in steel roof tile production and technology. Recognition of market needs has driven the company's success. Roofs produced by IKO Metals Europe have protected many thousands of homes and commercial buildings around the world since 1957.

Gerard Diamant, Classic, Heritage and Milano Tiles, Shakes, Shingles and Slates form the basis of an ever-growing range of profiles that are in regular demand across Europe and throughout the rest of the World.

Our company's vision is to provide innovative high quality roofing systems that everyone aspires to have on their home. Our company's core values include a willingness to meet all challenges, to conduct our affairs with honesty and integrity and, very importantly, to provide our customers with genuine value for money.

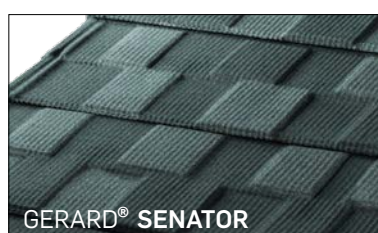
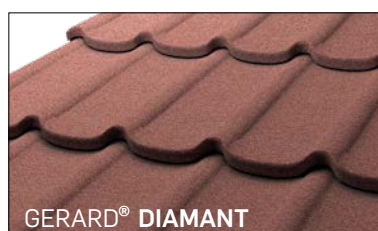
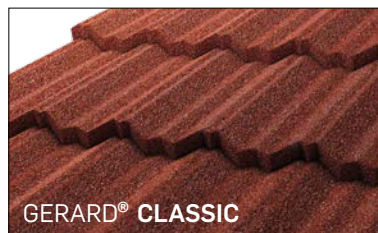

CONTENTS

1 IMPORTANT	4	10 NAIL POSITIONING	23
Storage and Handling	4	Diamant Tiles	23
Pitch	4	Classic Tiles	24
Non-standard Elements	4	Heritage Tiles	25
Roof Traffic	4	Corona Shake	26
Improper Tools	4	Senator Shingle	27
Cutting with a Saw	4	Milano Tiles	28
Installation Under Extremely Cold Conditions	4	Alpine Slate	29
Safety	5	11 EAVES FLASHING	30
Wet Surface	5	Option 1	30
Responsibility	5	Option 2	31
Packaging	5	12 RIDGE	32
Handling	5	Cutting and Bending Tiles	32
2 TOOLS	6	Installation	33
3 GERARD TILES	7	13 HIP	34
4 ACCESSORIES	8	Cutting and Bending Tiles	34
5 ROOF STRUCTURE	10	Installation	35
Underlay	10	14 BOX BARGE	36
Ventilation Space	10	Cutting and Bending Tiles	36
Thermal Insulation	10	Installation	37
Vapour Barrier	10	Box Barge End	38
6 LAYING THE UNDERLAY	11	15 SCRIBED BOX BARGE	40
7 BATTENS	12	Installation	40
Counter Batten	12	16 RIDGE - SINGLE SLOPED ROOF	41
Tile Battens	12	Installation	41
Batten Fixing	12	17 WALL FLASHING	42
Ridge Batten	12	18 TOP WALL FLASHING	44
Gable	12	19 MILANO RIDGE WALL FLASHING	45
Hip Batten	13	Installation	45
Eaves	13	20 VALLEY	46
Valley	14	Cutting and Bending Tiles	46
Batten Spacing	16	Installation	47
Installation Procedure	17	21 CHIMNEY FLASHING	48
8 TILE INSTALLATION	19	Option 1	48
Interlocking of the Tiles	19	Option 2	50
Tile Laying	20	22 ROOF WINDOW	52
Tile Laying at the Hip	21	23 INSTALLING ACCESSORIES	54
9 NAILING TECHNIQUE	22	Vents, Outlets	54
		Platform, Steps	55
		Solar Holder	56
		24 MANAGEMENT OF THE WORK SITE	57
		Estimating Materials	57

1 IMPORTANT

STORAGE AND HANDLING

Ideally tiles and accessories are stored indoor in a warehouse. If stored outside, it should be kept in a sheltered place and a well-sealed waterproof cover must be placed over the Gerard roofing tiles and accessories to keep them dry and prevent damage to the substrate. Pallets should be stored on a 'sealed' floor - such as concrete, where the surface is sealed in some manner to prevent moisture rising up from the ground.

PITCH

Classic, Heritage and Milano tiles can be installed from 12° to 90° while Diamant from 14° to 90°. Shakes, Shingles and Slates can be installed from 15° to 90°.

NON-STANDARD ELEMENTS

When installing non-standard elements or gutters above the level of the roof, it is strongly recommended that materials that could cause corrosion (e.g. Cu, stainless steel...) are NOT used.

ROOF TRAFFIC

Soft-soled shoes must be worn when walking on the roof.

When moving around the roof, avoid buckling the tiles by placing weight on the balls of the feet, directly over the batten, in the pans of tiles.

Traffic on the roof should be kept to a minimum to avoid possible damage to the tiles. Panels should be installed by working progressively from the top of the roof to the bottom, so that completed sections are not crossed more than necessary to complete the installation.

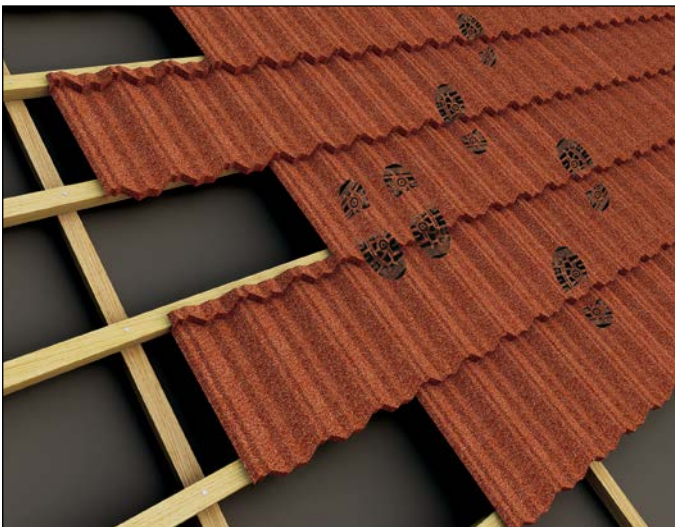

IMPROPER TOOLS

Only tools recommended by IKO Metals Europe should be used. Tools such as angle grinders must NOT be used as swarf (metal filings) will corrode and leave a red rust stain on the surface.

CUTTING WITH A SAW

When cutting tiles with a metal cutting saw (which has been approved by IKO Metals Europe), special (tipped) metal cutting blades should be used. Cutting should be performed with the chip-coated surface facing downwards to reduce the amount of swarf adhering to the chip coating. Failure to do so will result in rust stains on the tile surface.

A stable bench should be used when cutting tiles with a saw. Installers should always wear safety equipment recommended by the saw and blade manufacturers.



INSTALLATION UNDER EXTREMELY COLD CONDITIONS

Gerard roofs can be installed in areas that are subject to lengthy periods of extreme cold. Special care is needed during installation in winter conditions to prevent damage to the surface coatings:

1. Tiles and accessories should be warmed (stored in a warm place or lightly warmed – NOT OVERHEATED) before either cutting or bending.
2. The use of nailing guns is NOT recommended in very cold conditions.
3. The use of a nail punch to drive in the final 5 mm of the nail is recommended.

1 IMPORTANT

SAFETY

Please ensure that local safety regulations are followed and appropriate personal protective equipment is used at all times. Care should be taken to ensure that all live electrical cables are well clear of any nailing positions.

WET SURFACE

To prevent surface damage it is important not to walk or work on the roof when it is wet.

RESPONSIBILITY

It is the responsibility of the architects, builders and roof installers to ensure that all the elements of the roof (e.g. underlay, ventilation space, thermal insulation and vapour barrier) are constructed correctly.

PACKAGING

Tiles and accessories are stored on wooden pallets and protected by a plastic cover. A pallet consists of between 250 and 350 tiles. This represents a roofing area of between 115 and 178 m². The base dimensions of tile pallets are 1430 x 1070 mm and in case of Diamant profile 1430 x 1120 mm. The maximum height of a pallet is 1000 mm. Tiles should be stacked on each pallet up to a maximum weight of 1150 kg.

HANDLING

Care should be taken when handling the tiles to avoid damage to the surface. If minor damage does occur, the finishing kit should be used to repair it.

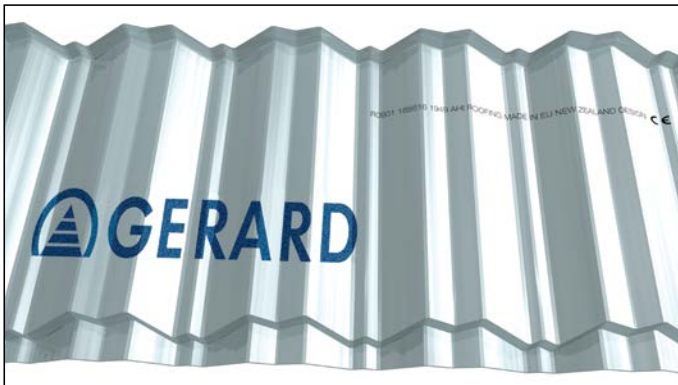

Reverse side of the tile

2 TOOLS

GUILLOTINE

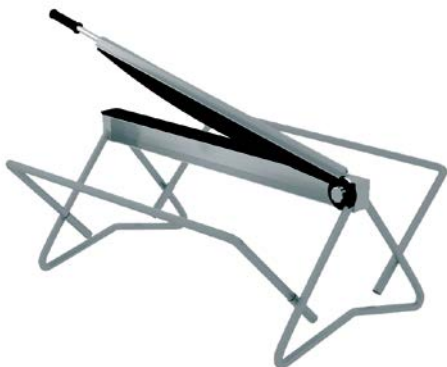

COMBINED BENDER



METAL ROOF ATTACHMENT



METAL CUTTING SAW

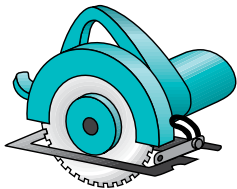

METAL CUTTING BLADE

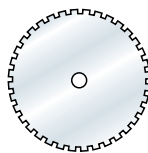

HAMMER

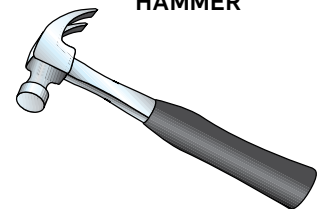

HAND PLIERS

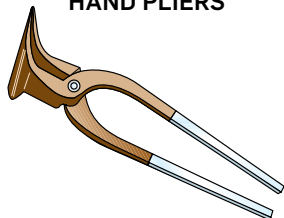

SHEARS PELIKAN

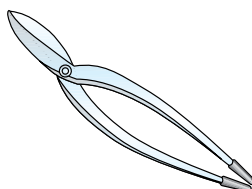

COLOURED STRING

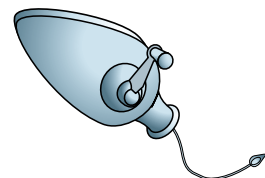

MEASURING ROD

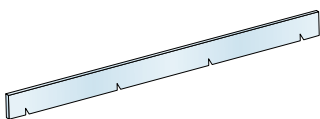

BEVEL

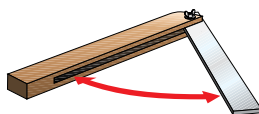

TAPE MEASURER

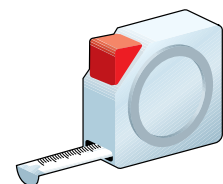

PNEUMATIC NAILER



GAS NAILER

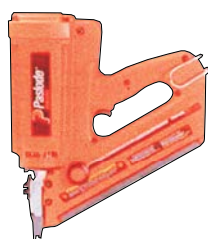

SOFT-SOLED SHOES



3 GERARD TILES

GERARD CLASSIC



Length of Tile: 1320 mm
Length of Cover: 1265 mm
Width of Cover: 369 mm
Tiles/m²: 2.14
Minimum Pitch: 12° (21%)

GERARD DIAMANT



Length of Tile: 1345 mm
Length of Cover: 1270 mm
Width of Cover: 398 mm
Tiles/m²: 1.98
Minimum Pitch: 14° (25%)

GERARD HERITAGE



Length of Tile: 1330 mm
Length of Cover: 1250 mm
Width of Cover: 367 mm
Tiles/m²: 2.18
Minimum Pitch: 12° (21%)

GERARD CORONA SHAKE



Length of Tile: 1330 mm
Length of Cover: 1250 mm
Width of Cover: 371 mm
Tiles/m²: 2.16
Minimum Pitch: 15° (27%)

GERARD SENATOR SHINGLE



Length of Tile: 1330 mm
Length of Cover: 1260 mm
Width of Cover: 369 mm
Tiles/m²: 2.15
Minimum Pitch: 15° (27%)

GERARD MILANO



Length of Tile: 1335 mm
Length of Cover: 1215 mm
Width of Cover: 369 mm
Tiles/m²: 2.23
Minimum Pitch: 12° (21%)

GERARD ALPINE



Length of Tile: 1335 mm
Length of Cover: 1250 mm
Width of Cover: 368 mm
Tiles/m²: 2.18
Minimum Pitch: 15° (27%)

4 ACCESSORIES

BARREL 205

Length of cover: 405 mm



BARREL 205 END DISC



BARREL 205 MOULDED END

Length of cover: 400 mm



BARREL 205 T-RIDGE



Y-HIP BARREL 205 15-30°



Y-HIP BARRELL 205 30-45°



ANGLE TRIM

Length of cover: 370 mm



ANGLE TRIM END



ANGLE TRIM MOULDED END



Y-HIP ANGLE TRIM



FLAT SHEET

Dimensions: 2000 mm x 450mm



BOX BARGE 2000

Length of cover: 1900 mm



BOX BARGE SCRIBED 140 (LEFT/RIGHT)

Length of cover: 1100 mm (Diamant: 1194 mm)



MILANO RIDGE FLASHING

Length of cover: 1215 mm



SIDE WALL FLASHING

Length of cover: 1900 mm



EAVES FLASHING

Length of cover: 1900 mm



4 ACCESSORIES

COVER FLASHING

Length of cover: 1250 mm



BOX BARGE DEEP 180

Length of cover: 1250 mm



SIDE WALL FLASHING SCRIBED (LEFT/RIGHT)

Length of cover: 1100 mm (Diamant: 1194 mm)



VALLEY 400

Length of cover: 1200 mm



SANITARY VENT HV15-15



SANITARY VENT HV110



COWL VENT RV75



TUBE TILE 1 PIPE



TUBE TILE 2 PIPES



STEP



PLATFORM



SOLAR HOLDER



SAFETY HOOK



REPAIR KIT



FASTENER 30 mm, 50 mm

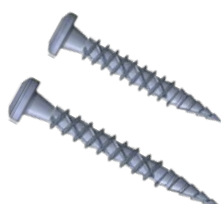

NAILS PACK 15° COILS



NAILS 50 x 2.8



SCRAILS 16° COILS

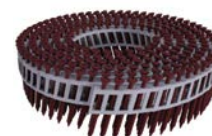

5 ROOF STRUCTURE

The conventional design of pitched roofs requires two ventilation zones to control condensation.

Modern roof construction prescribes one ventilation zone and the installation of vapour permeable underlay, which can be used in both cold and warm roofs.

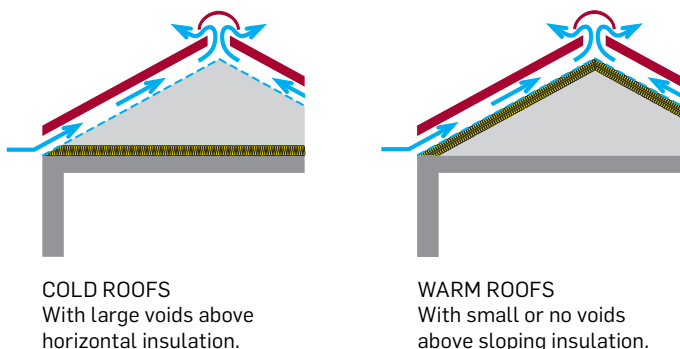

The harmful effects of condensation and ice damming can be avoided by ensuring that all the components of the roof are correctly installed. The tiles should be installed on a traditional batten structure. The roof should be designed as a ventilated system with an open-ended ventilation space, breathable underlay, thermal insulation and vapour membrane. It is recommended that a heat loss calculation is carried out according to local regulations.

UNDERLAY

Breathable underlays allow water vapour to escape through the material by diffusion. They have a sufficiently fine structure to prevent liquid water penetration under service conditions. They fulfil all the other demands made on a roof underlay: the outflow of eventual condensation moisture or rain and snow water, caused by improper design of the roof or poor workmanship.

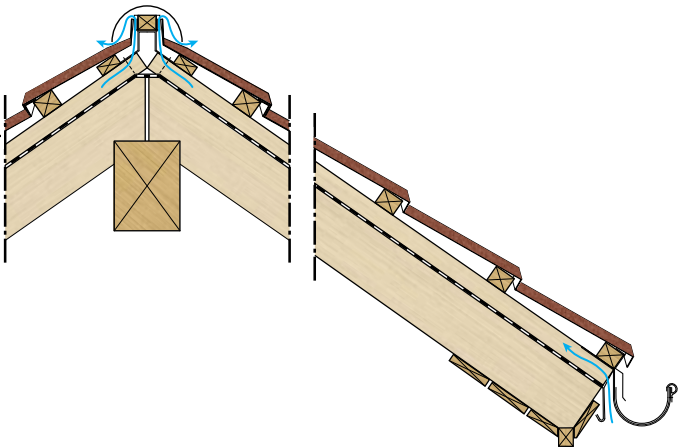

VENTILATION SPACE

A ventilation space should be provided above the underlay, by means of eaves and ridge ventilation. This is achieved by the installation of counter battens nailed to the rafters. The height of the counter battens can be from 25 to 50mm. Thicker counter battens enlarge the ventilation space, thus enabling humidity to exit more efficiently. To achieve good air circulation, an air inlet in the eaves and an air outlet in the ridge should be ensured.

The eaves inlet opening should measure:

- Min. 2 ‰ (equivalent to 0.2%) of the corresponding area of roof OR
- Min. 200 cm² per m of eaves length (equivalent to a continuous, unobstructed gap 2 cm wide).

An air outlet at ridge level or on top of the roof should measure:

- Min. 0,5 ‰ (equivalent to 0.05%) of the corresponding area of roof OR
- Min. 50 cm² (equivalent to a continuous, unobstructed gap 0.5 cm wide) per m of ridge length.

Depending on the rafter length (a), the diffusion-equivalent air layer thickness (s_d) of the layers installed underneath the ventilated space should not be less than:

- $a < 10 \text{ m} : s_d > 2 \text{ m}$
- $a < 15 \text{ m} : s_d > 5 \text{ m}$
- $a > 15 \text{ m} : s_d > 10 \text{ m}$

THERMAL INSULATION

Adequately sized thermal insulation will reduce energy costs, prevent the possibility of condensation and the formation of ice dams in regions that experience severe winters. The minimum thickness of the insulation should be calculated in accordance with the local building legislation.

VAPOUR BARRIER

The vapour barrier ensures that only a limited amount of humidity is transported through the roofing structure. This is always laid on the warmer side of the thermal insulation. It is important that a special adhesive tape is used to securely seal any overlaps in the vapour barrier, the junctions with walls and around any pipes, chimneys, antennas, window openings and such like that may penetrate the roof surface. There should not be any leaking joints in the vapour barrier.

6 LAYING THE UNDERLAY

- The underlay is traditionally laid in runs parallel to the eaves with an overlap over the adjacent roll. The width of the overlap depends on the requirements of the manufacturer and on local regulations. The traditional practice is to overlap waterproofed sheets by 150 mm.
- It is important that all protrusions (pipes, wires, chimneys ...) through the underlay are waterproofed.
- When installing a roof window, lay a window-protective flashing (gutter) above the window opening to divert possible running water away from the opening.
- It is recommended that you stick the underlay on the custom made eaves protection flashing which is installed underneath the underlay at the eaves edge. The function of the eaves protection flashing is to provide a support for the underlay at the end of eaves and to direct water away from the roof (**refer page 13; BATTENS/ Eaves**).
- Waterproofed sheets of underlay can be bonded together with an integrated self-adhesive tape or adhesive, which contributes to better windproofing for the roof structure.

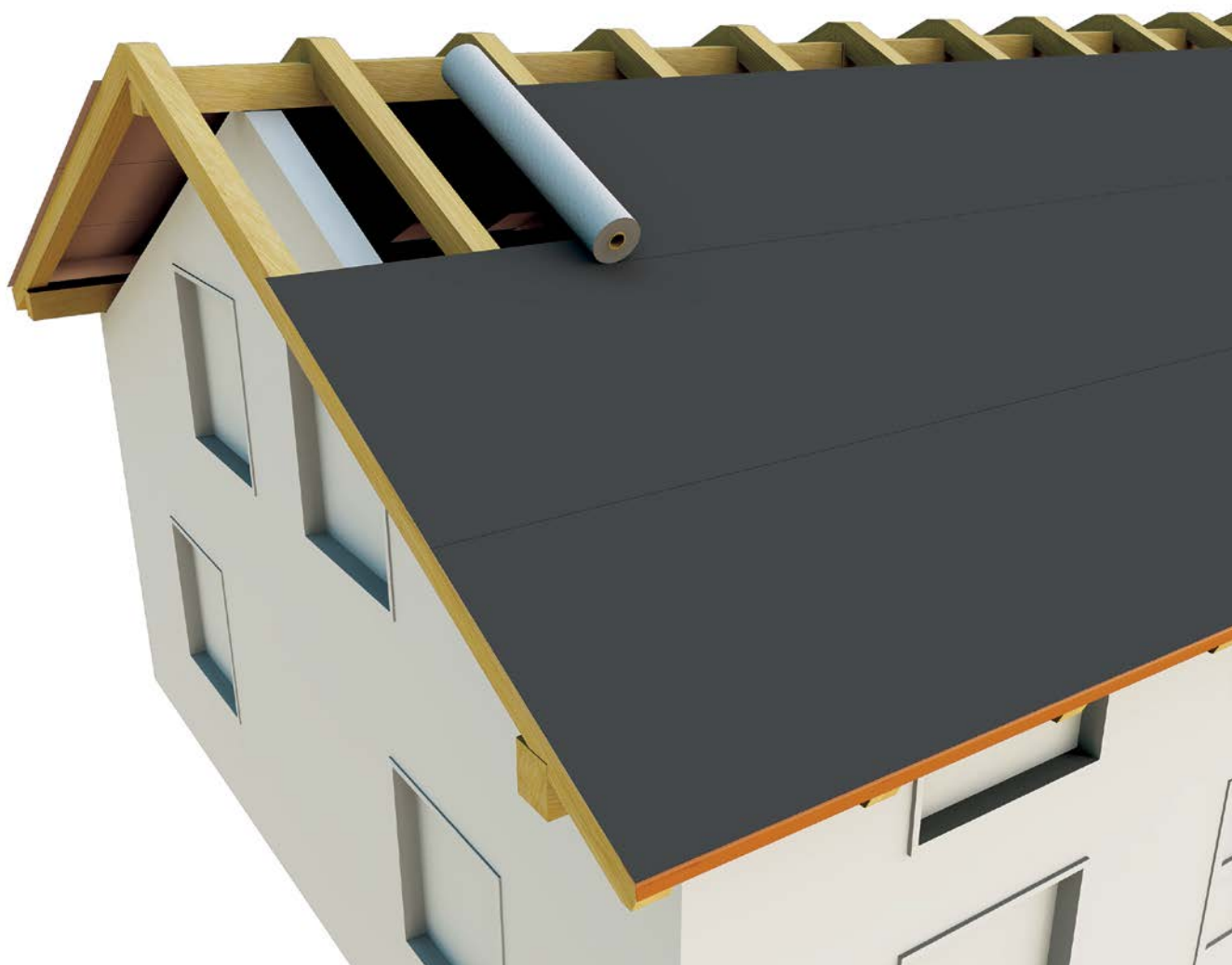

7 BATTENS

COUNTER BATTENS

Counter battens (Ventilation Space Battens) provide a ventilation space between the underlay and the roof covering (*refer to page 10; ROOF STRUCTURE/ Ventilation Space*). Rafters should be lined up before the roofer begins work (this is the builder's responsibility). When re-roofing, counter battens should be lined up. The recommended counter batten dimension is 50 x 80 mm. The minimum counter batten height is 25 mm.

TILE BATTENS

Rafters can be set at various centres depending on the type of construction and the local regulations. In most situations, the following batten sizes are recommended based on rafter spacing.

Recommended Rafter or Truss Centres	Batten Size
up to 600 mm	30 x 40 mm
900 mm	40 x 50 mm
1200 mm	50 x 50 mm
1500 mm	50 x 65 mm (on edge)
1800 mm	50 x 75 mm (on edge)

NOTE: If necessary, larger battens may be used.

BATTEN FIXING

Wind pressure applies wind uplift load to the fasteners. When fixing counter battens to rafters and tile battens to counter battens, it is recommended to use screws or twist shank nails for additional holding power. In regions subject to strong winds, special attention should be paid to the method of fixing the counter battens and tile battens.

RIDGE BATTEN

Install the top ridge batten onto the ridge bracket (Option 1) or along the batten under-structure (Option 2). The height of the top ridge battens can vary depending on the slope of the roof. This setup must be accurate as the barrel will be installed onto the ridge batten. To provide an air outlet (*refer to page 10; ROOF STRUCTURE/ Ventilation Space*) a gap must be ensured between the ridge batten and the upstand of the top tile. Spacers (pieces of wood) can be installed on both sides of the ridge batten (Option 2) to provide this opening (*refer to page 33; RIDGE/ Installation*).

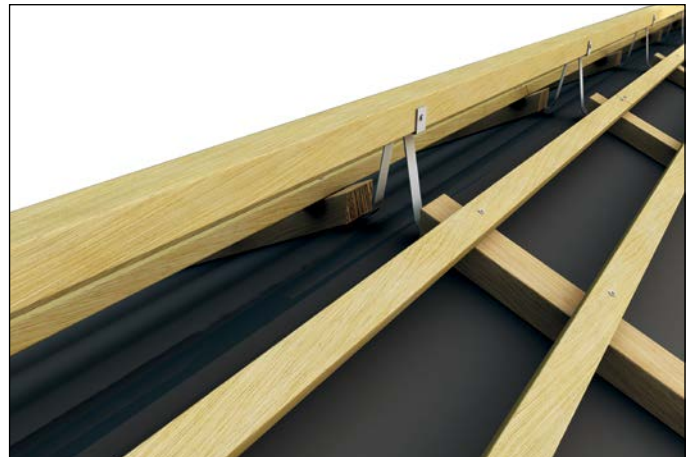

Option 1: Ridge batten - installation with bracket



Option 2: Ridge batten - installation with batten understructure

GABLE

Install a 40 x 50 mm batten across the tile batten. Fix the barge board into the counter batten and gable batten. The underlay should be turned up at the gable end of the roof. Note that the edge of the tile is bent up under the barge cover when finishing the installation of tiles. This will ensure complete weather security.



7 BATTENS

HIP BATTEN

Install the top hip batten onto the ridge-hip bracket (Option 1) or along the batten under-structure (Option 2). The height of the hip batten can vary depending on the slope of the roof. This setup must be accurate as the barrel will be installed onto the hip batten.

To provide an air outlet (*refer to page 10; ROOF STRUCTURE/ Ventilation Space*), a gap must be ensured between the hip batten and the upstand of the tile. Spacers (pieces of wood) can be installed on both sides of the hip batten to provide this opening (*refer to page 35; HIP/ Installation*).



Option 1: Hip batten - installation with bracket



Option 2: Hip batten - installation with batten understructure

EAVES

Install eaves protection flashing underneath the underlay. It can go behind the gutter into the open (Option 1), or over and into the back of the gutter (Option 2). The use of self-adhesive tape is recommended to bond the underlay and the eaves protection flashing where they overlap.

The air inlet should be protected by a metal or plastic mesh to prevent insects, birds or small animals entering the ventilation space.



Option 1: Protection flashing going behind the gutter



Option 2: Protection flashing going into the gutter

7 BATTENS

VALLEY

Measure and construct the valley very carefully as it is an important part of the roof. The following details suggest two ways that the valley lining may be fitted. Local practice, building regulations and site conditions will dictate the final method used. If not regulated by local legislation, it is recommended to use a valley made from approx. 50 cm wide, painted aluminium-zinc alloy coated steel or aluminium sheet. This is of particular importance in areas prone to harsh winters. Secure the valley with a clip. Never nail inside the valley.

1. INSTALLATION OF THE VALLEY ON THE LEVEL OF THE COUNTER BATTEN SPACE

Tile battens are installed over the valley. The advantage of this method is a free choice of valley width. As the greater part of the valley is concealed beneath the tiles, it allows the use of wider valleys maintaining the aesthetic appearance of the roof. This is of particular importance in the case of extreme winter conditions and low pitches, where a wider valley helps overcome the consequences of ice damming.

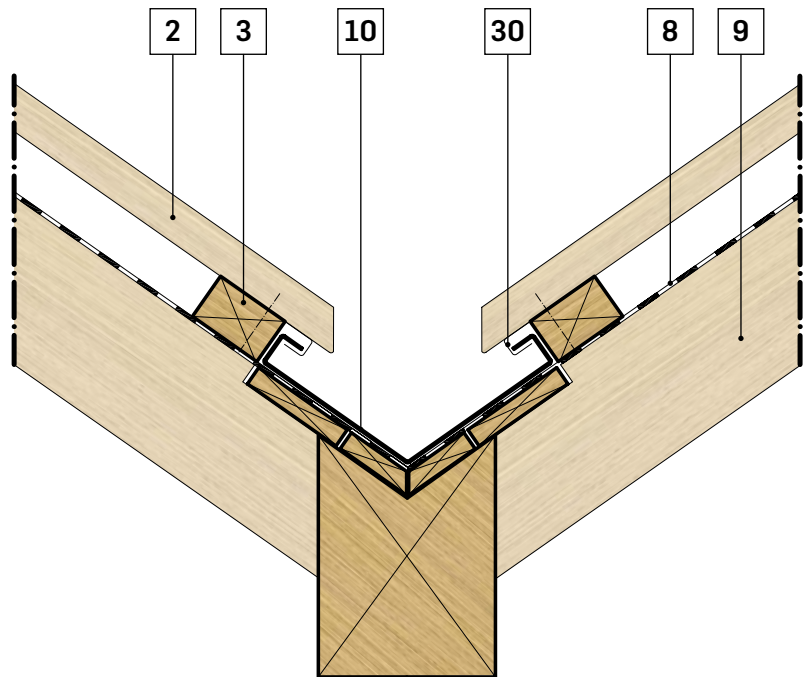

- 2 Tile Batten
- 3 Ventilation Space Batten
- 8 Underlay
- 9 Rafter
- 10 Valley
- 30 Clip

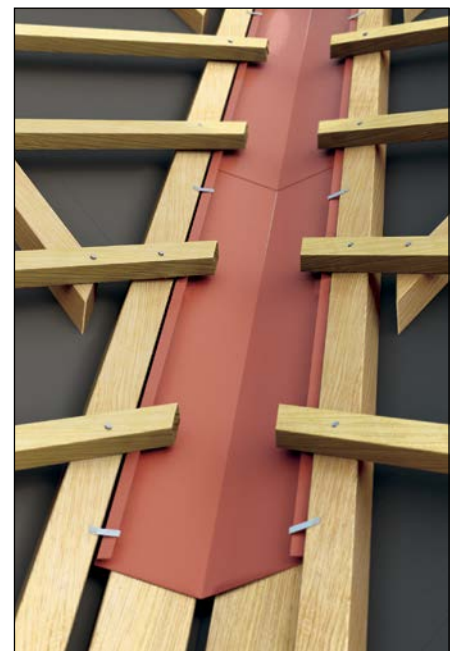
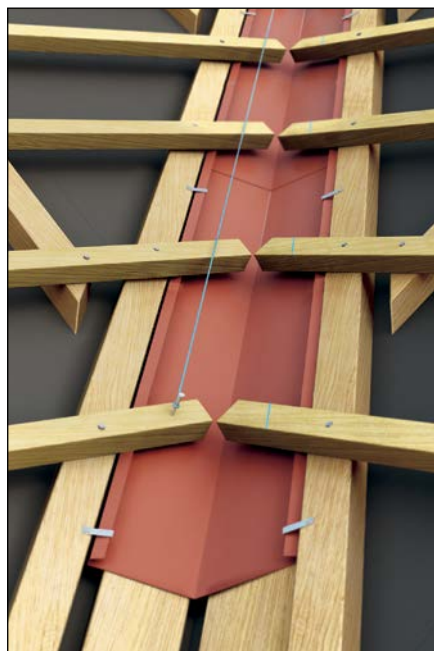
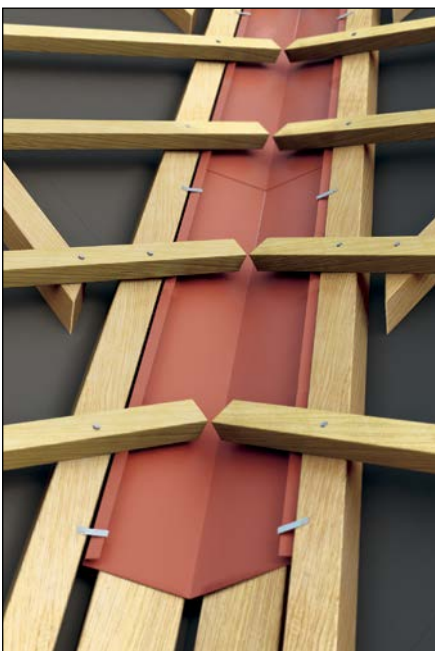

7 BATTENS

2. INSTALLATION OF THE VALLEY ON THE LEVEL OF THE TILE BATTEN SPACE

Ensure that the tile battens end at the vertical edge of the valleys. The advantage of this method is the easier installation of the valley around dormers where the valley ends on top of the tiles.

- 2 Tile Batten
- 3 Ventilation Space Batten
- 8 Underlay
- 9 Rafter
- 10 Valley
- 30 Clip

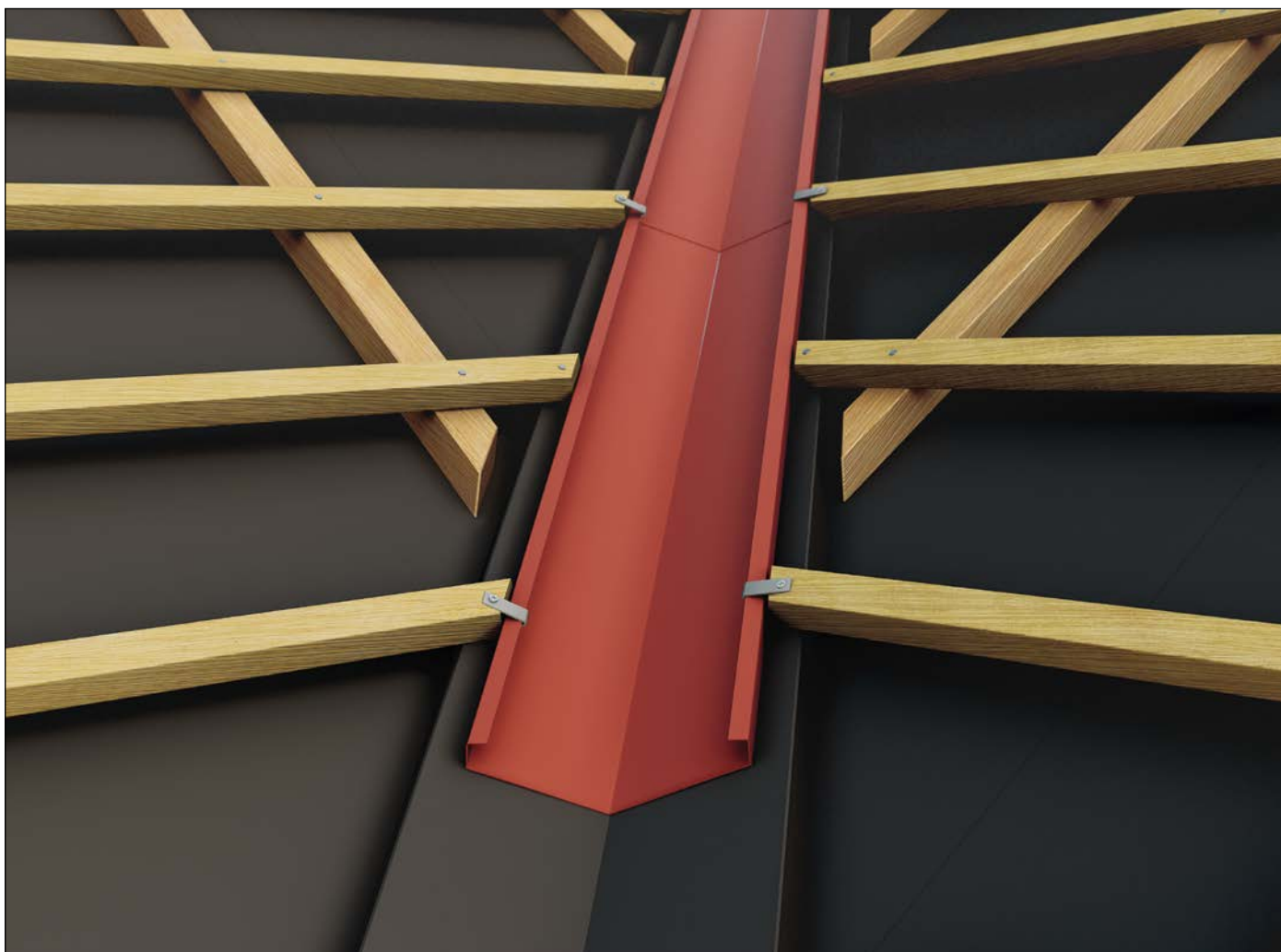
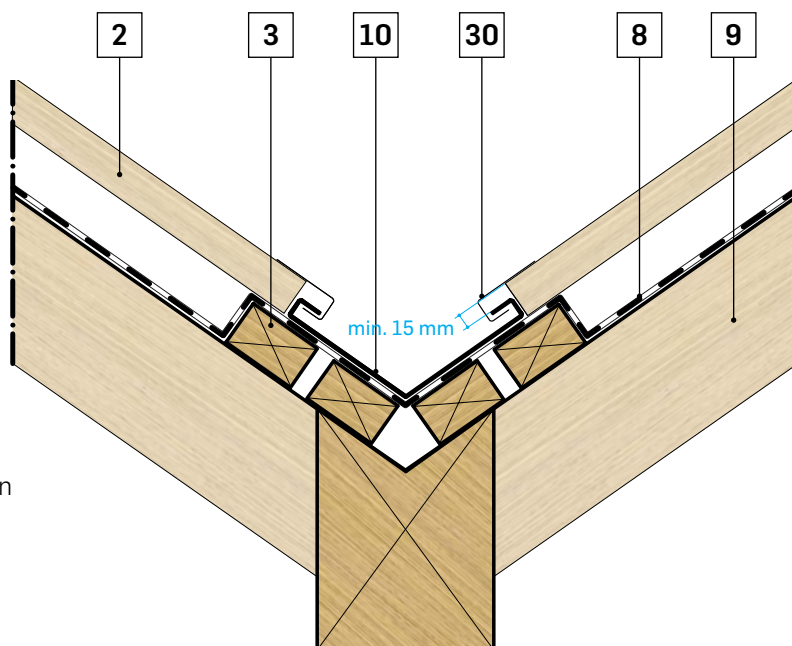

7 BATTENS

BATTEN SPACING

The most critical factor in laying the tiles is accurately setting out the tile battens. If this is not done accurately then the tiles will not fit together correctly.

All measurements should be made from the front of the battens. This is the surface where tiles will be fixed to the battens. The batten spacings for all profiles are listed below:

BATTEN SPACING FOR SENATOR SHINGLES

1. An intermediate batten is obligatory for roof slopes of 15° to 30°. The distance between the main battens is 369 mm. The intermediate batten is positioned at a distance of 185 mm to 190 mm from the lower edge of the lower main batten.
2. For slopes above 30°, an intermediate batten is recommended, but is not obligatory.

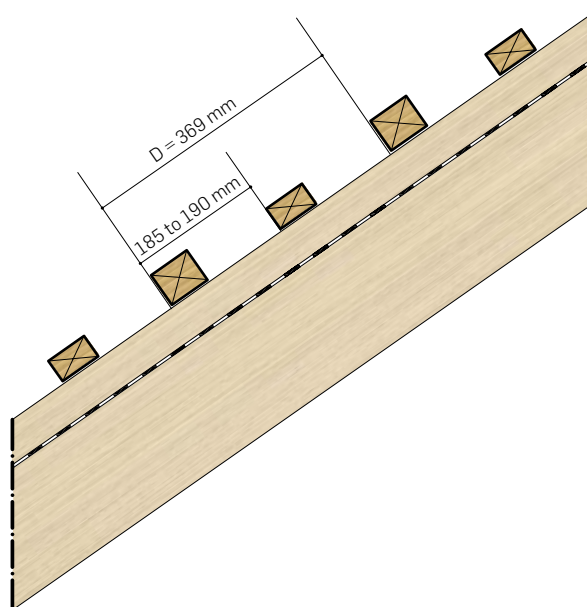
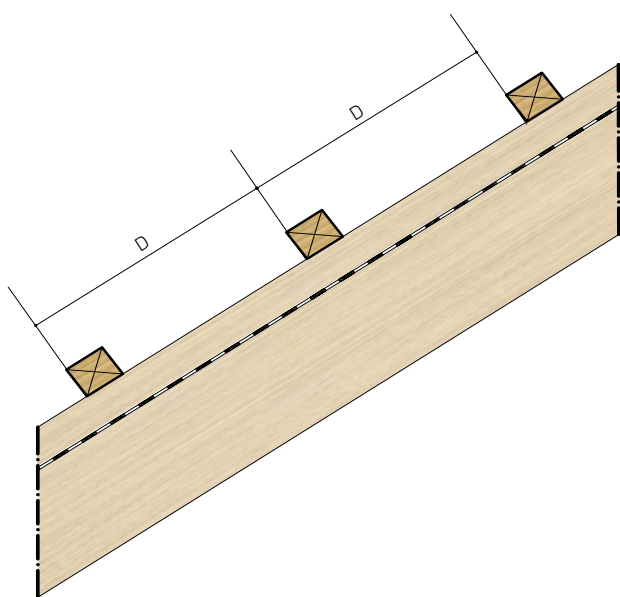

Name of the profile	Batten Size
Diamant Tile	398 mm
Classic Tile	369 mm
Heritage Tile	367 mm
Corona Shake	371 mm
Senator Shingle*	369 mm
Milano Tile	369 mm
Alpine Slate	368 mm

* Battening for Senator Shingles requires the use of intermediate battens (refer Batten Spacing for Senator Shingles).

7 BATTENS

INSTALLATION PROCEDURE

Measure up from the eaves edge ($D-3$ mm) to establish the position of the second batten. Use the measuring rod to measure the subsequent battens in direction from the eaves to the ridge.

Use coloured string to mark the position of the marking nails. If the rafter length does not accurately suit a full course of tiles, the top course will have to be cut and bent to fit, requiring the space between the top batten to the ridge to be less than usual.

Lay the battens in rows across the rafters against the marking nails, which will be removed after fixing the battens.



7 BATTENS

Thinner support battens are recommended for the top row at the ridge. This ensures that the top course of tiles follows the same pitch as the other courses. Ensure that the batten joints are staggered.

- 2 Tile Batten
- 3 Ventilation Space Batten
- 5 Ridge Batten
- 7 Ridge Bracket
- 8 Underlay
- 9 Rafter
- 18 Thinner Support Batten

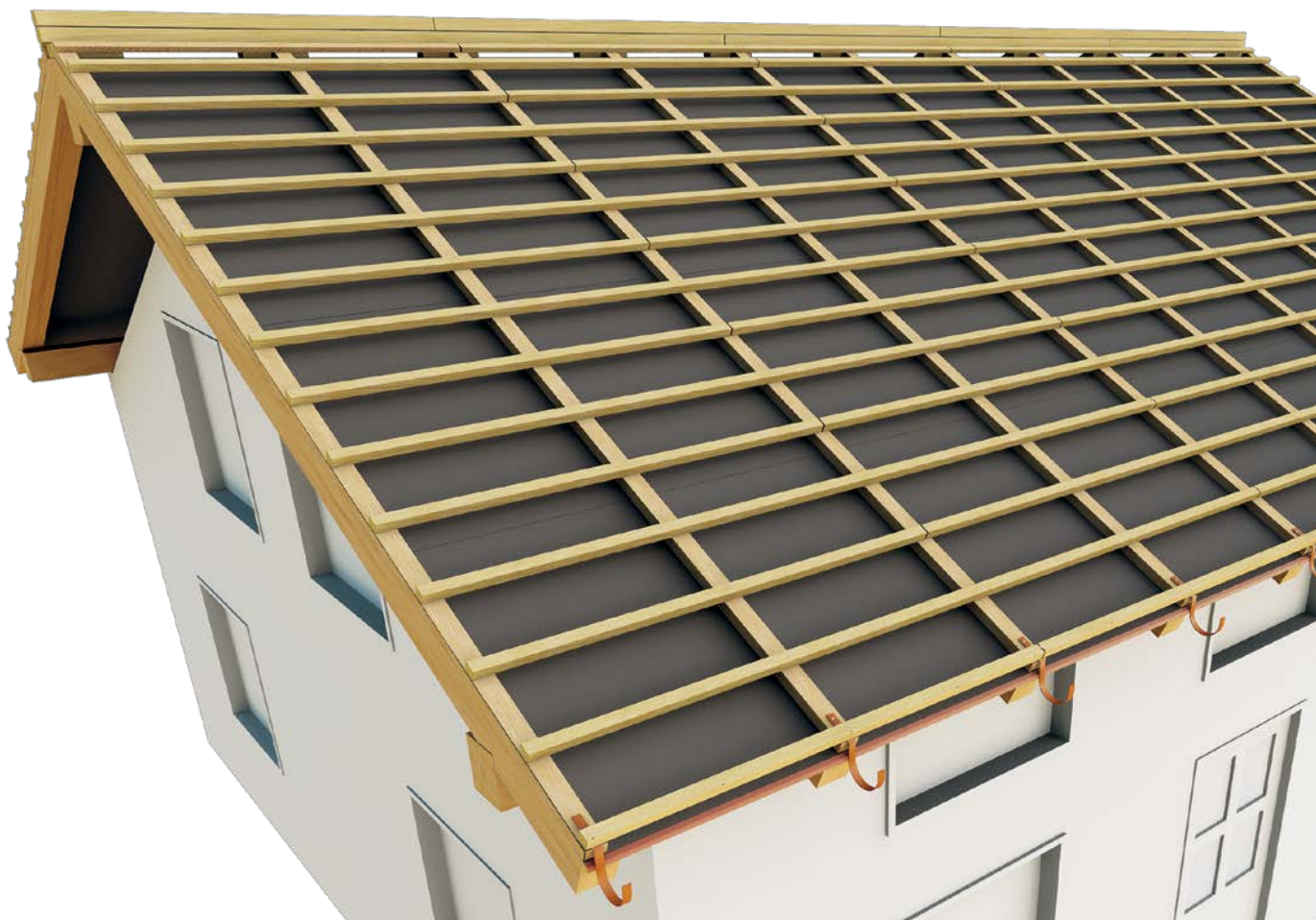
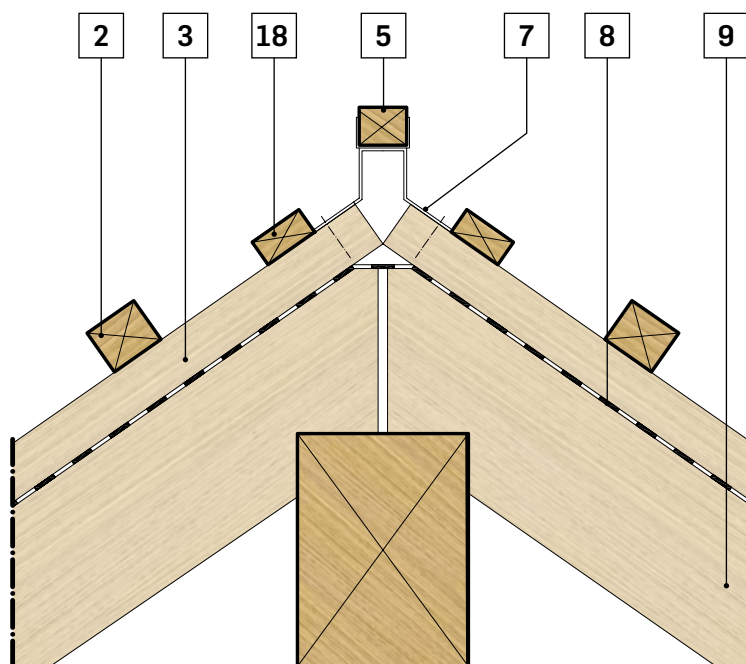

8 TILE INSTALLATION

INTERLOCKING OF THE TILES

Diamant Tile, Classic Tile, Heritage Tile, Milano Tile and Corona Shingle can be interlocked either right over left or left over right, but should be laid with the laps facing away from the prevailing winds or from discharging rain-water pipes or valleys. Where possible, the tiles should also be laid with the laps facing away from the normal line of sight.

Senator Shingles and Alpine Slates only interlock one way; Shingles are laid right to left and Slates are laid left to right along the roof.

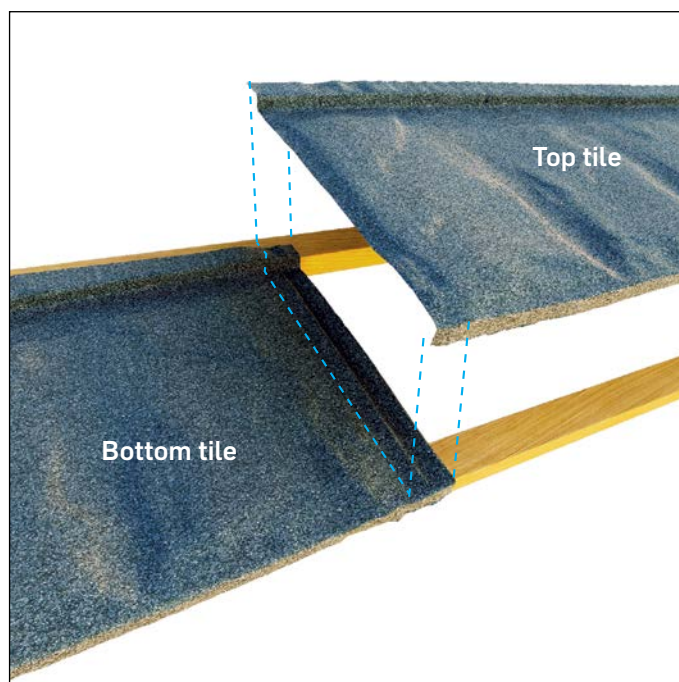
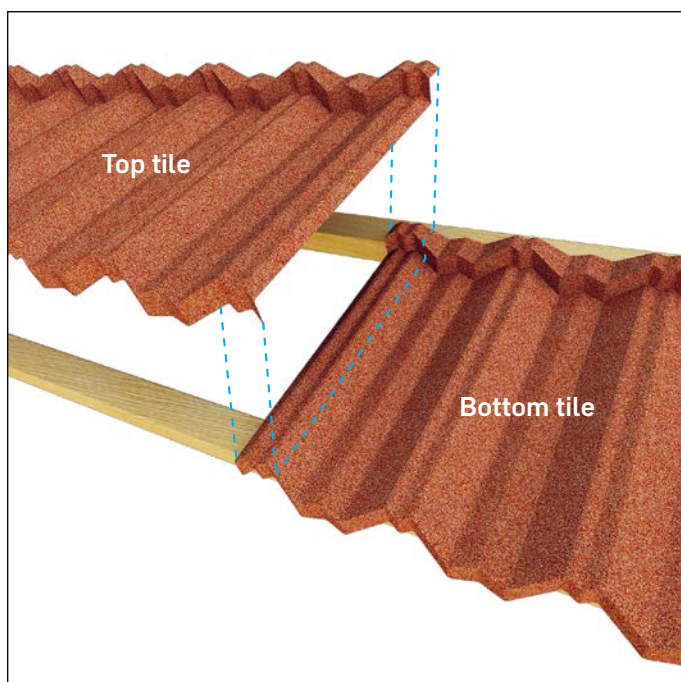
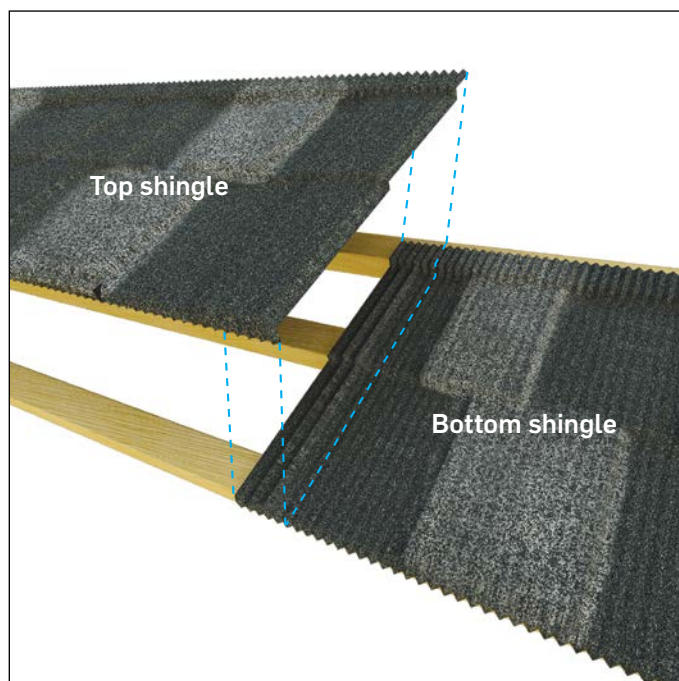
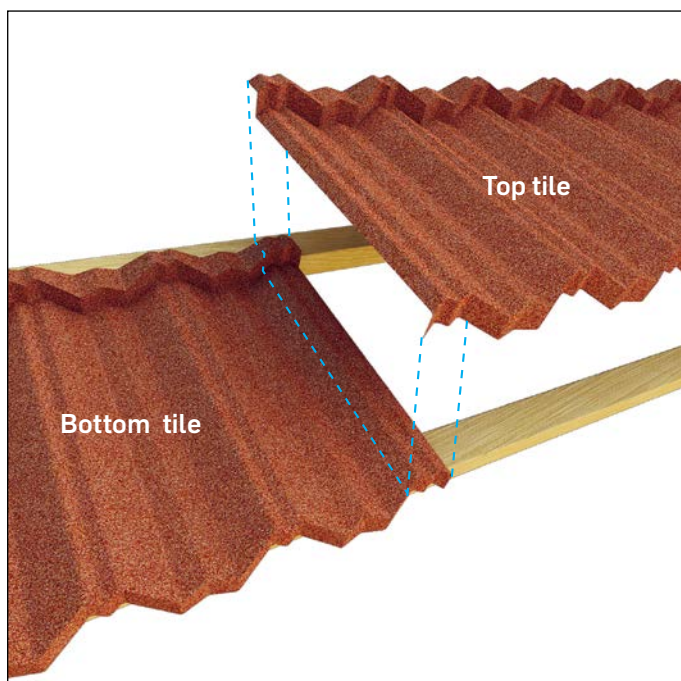

8 TILE INSTALLATION

TILE LAYING

Start installation from ridge towards the eaves. Lay the second course of tiles from the top from gable end to gable end, turning the edge of the end tiles up against the barge battens (**refer to page 37; BOX BARGE/Installation**). Nail these tiles in position through the flat of the back edge sitting on the batten.

Tiles are laid by lifting both tiles in the course above and sliding the next course under the nose of the tiles already in place. Starting from the course already laid, lay the tiles two courses at a time from end to end. The person laying the tiles should be two courses ahead of the person nailing.

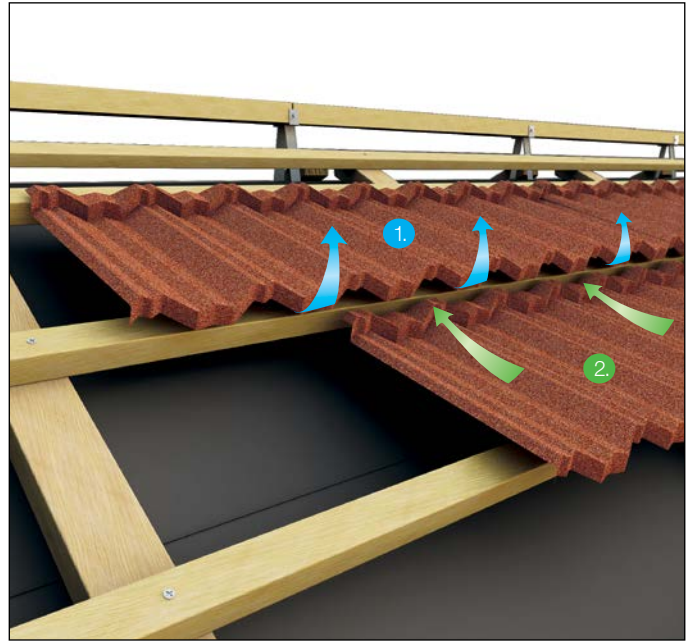

Stagger the tile laps down the roof, using parts of tiles at the gable end.

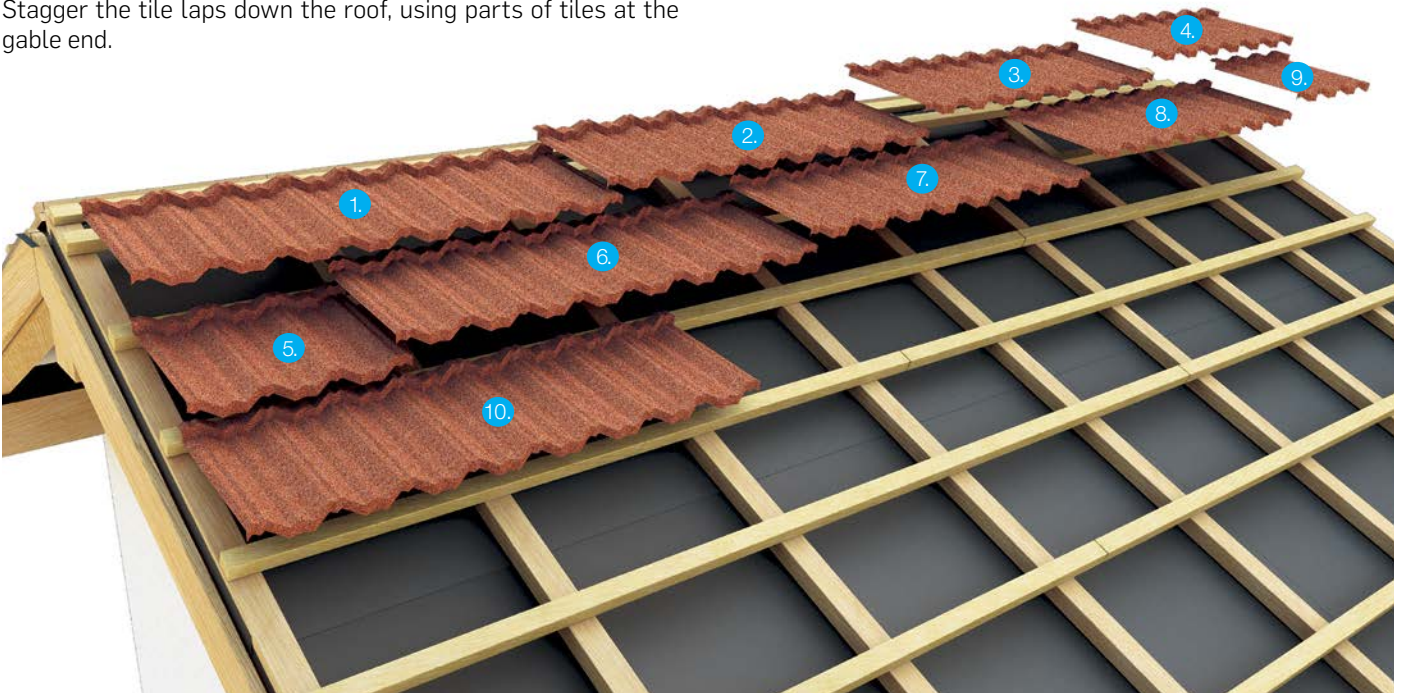

8 TILE INSTALLATION

TILE LAYING AT THE HIP

On the second course from the top, lay the top corner of the first tile approximately 150 mm from the hip batten. Continue to lay tiles towards the other hip until the last full tile will fit and secure them through the flat on the back of the tiles. Lay subsequent courses two at a time, both starting about the same distance from the hip batten.

To fill the gap between the last full tile and hip batten use parts of tiles. The amount of tile wastage can be reduced if each end of a full tile is cut and bent to fill the gaps.

If a small part of the tile (less than a module width) is required to fill the gap, it will be necessary to remove the adjacent full tile and insert a part tile. This will allow a full width tile to be cut to fit.

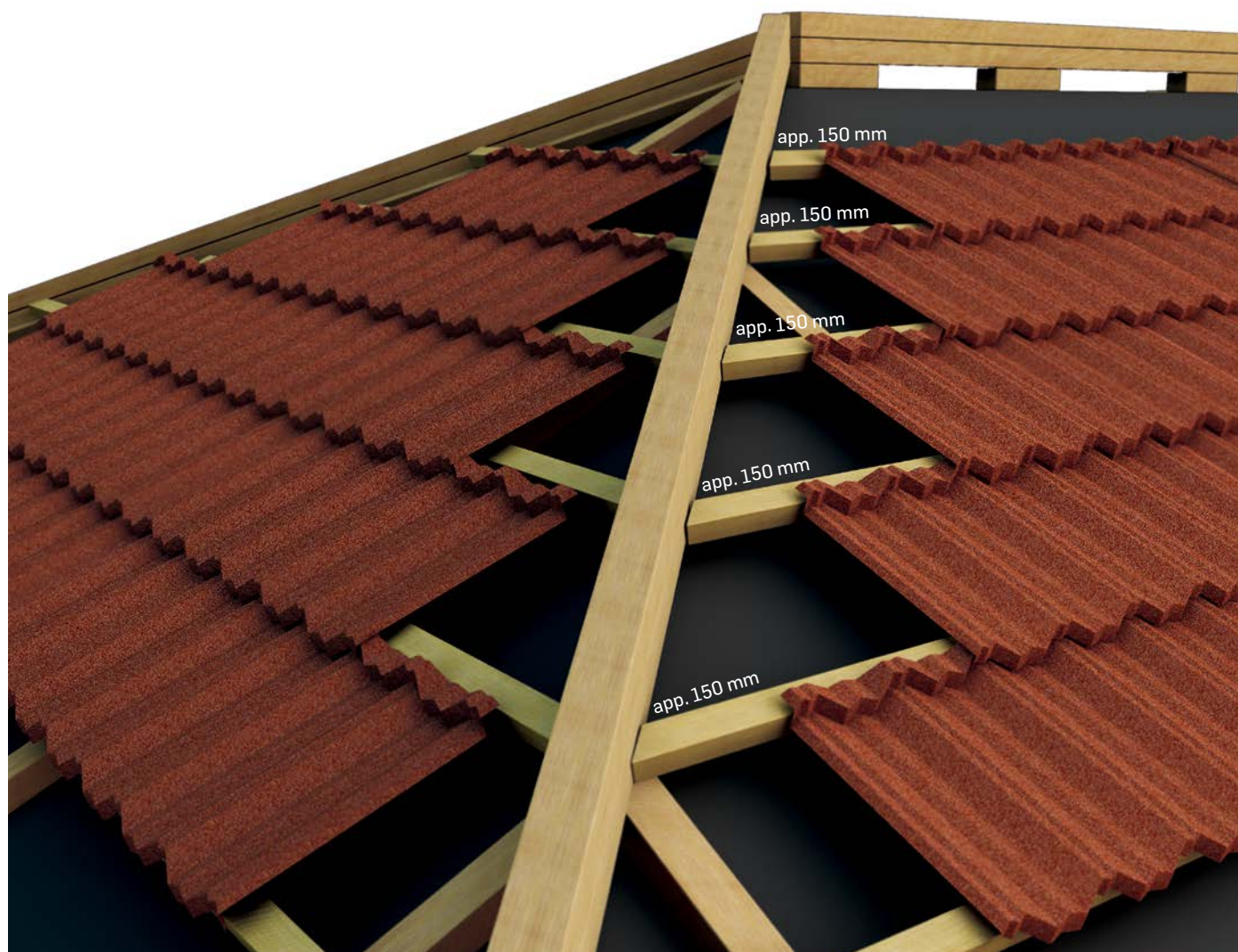

9 NAILING TECHNIQUE

Tiles are secured to the battens by nailing through the nose of the upper tiles and through the back up stand of the lower tile into the side of the battens. The positioning of the nails and the number of nails per tile are determined by the type and length of the tile (*refer to pages 23-29; NAIL POSITIONING*). The tiles should be fastened two courses above the tiles that are being laid.

Apply weight when nailing. The person nailing should stand on tile being installed facing the eaves.

Gun nailers can also be used to securely fasten the tiles.

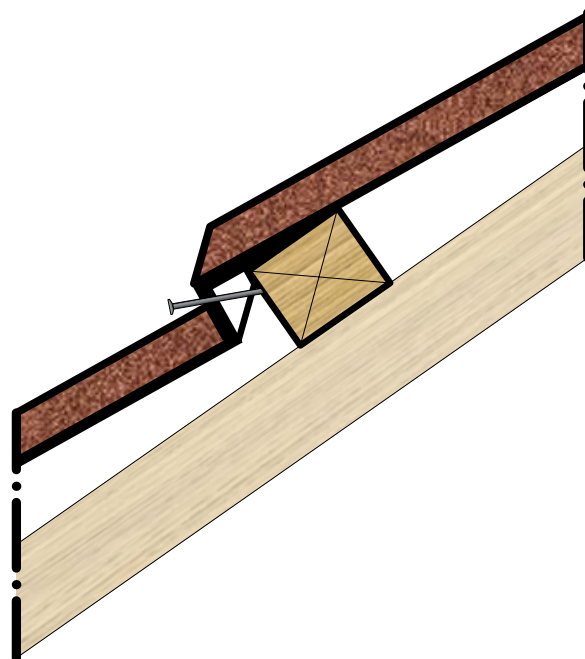

10 NAIL POSITIONING

The correct positions for nailing different profiles are shown below. Correct nailing ensures good holding of the tile and ample penetration of the nail, at the same time restricting nail penetration to a maximum of two thicknesses.

NOTE: In areas prone to extremely strong winds, installation must meet the local standards and by-laws and nailing should be at 8 points per tile.

DIAMANT TILES

Nails should be approximately 60 mm to the side of the centre of the pan of the tile and close to the bottom of the downturned flange.

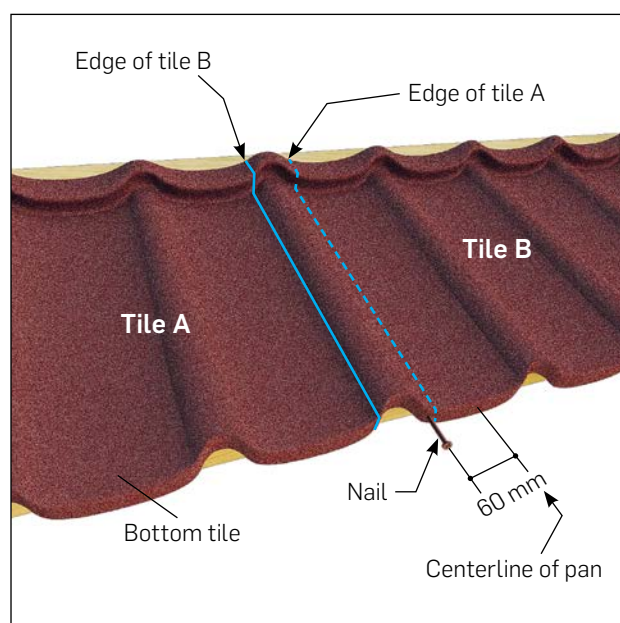
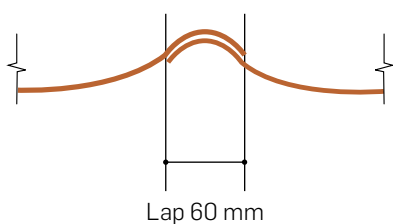
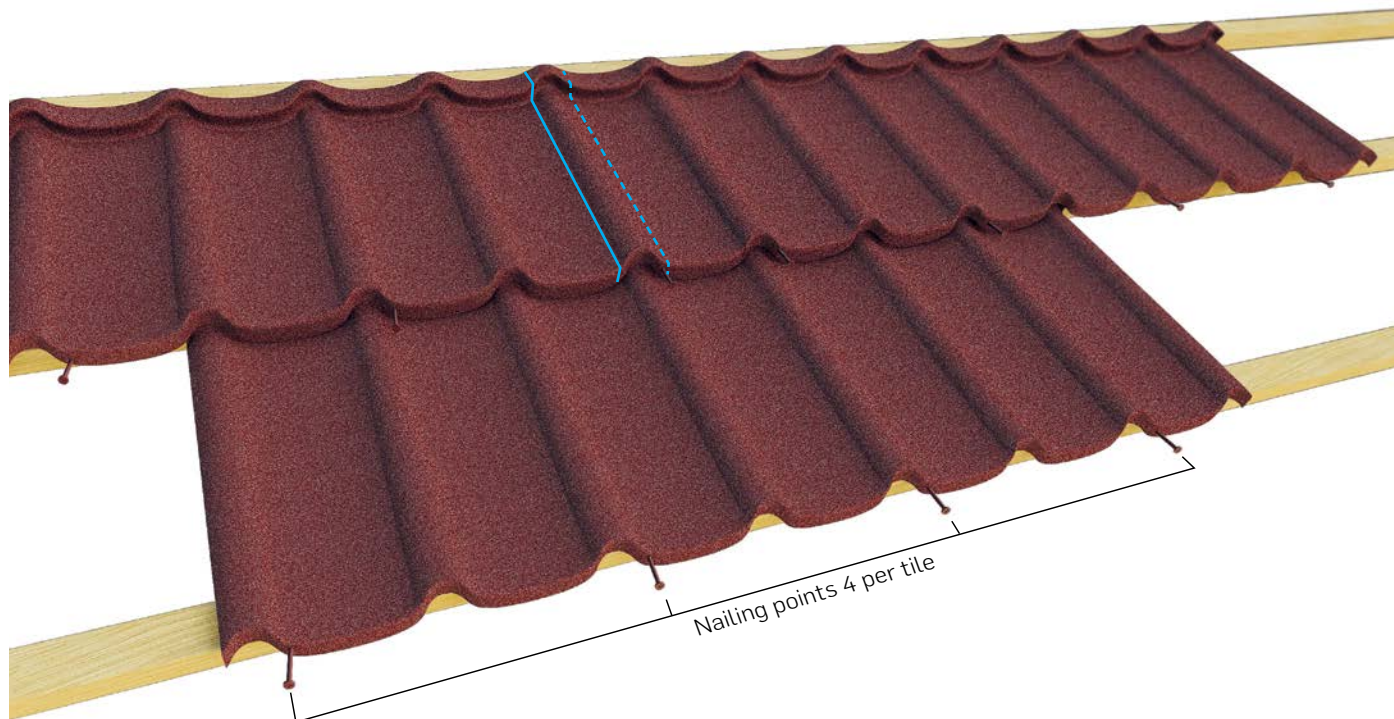

10 NAIL POSITIONING

CLASSIC TILES

Nails should be approximately 60 mm to the side of the centre of the pan of the tile and close to the bottom of the downturned flange.

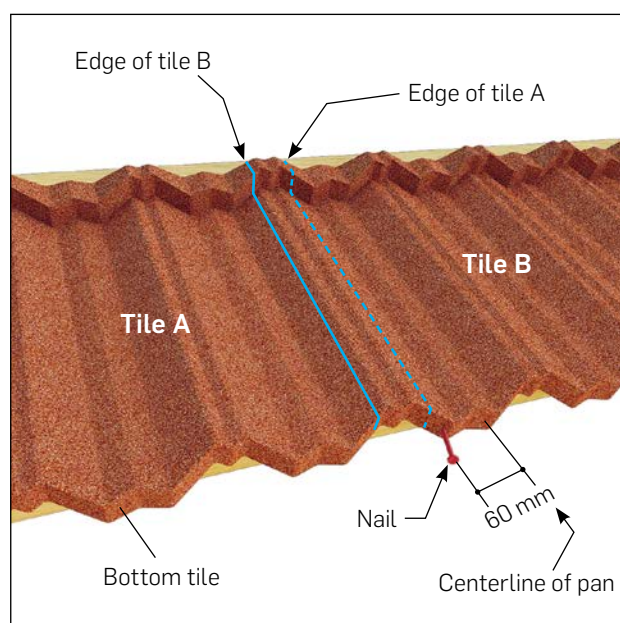
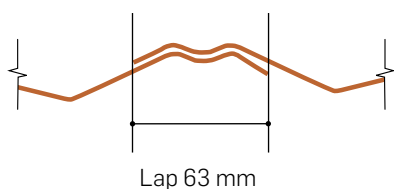
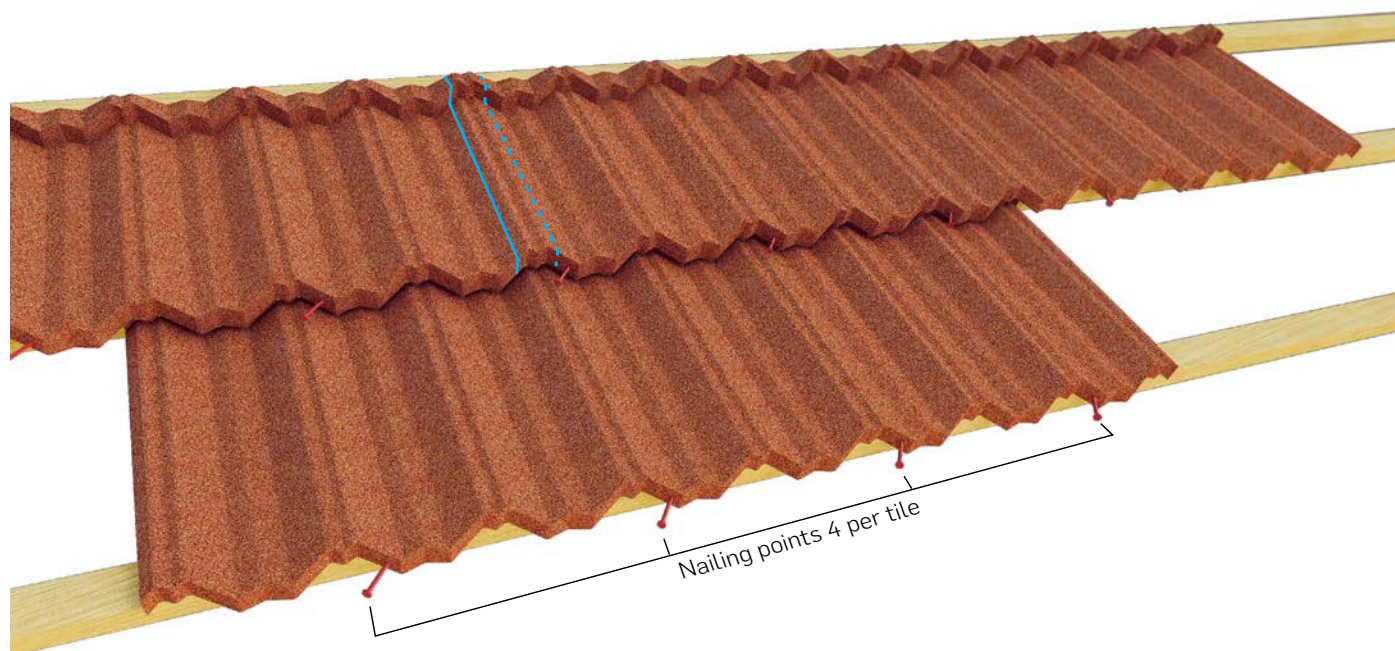

10 NAIL POSITIONING

HERITAGE TILES

Nails should be approximately 45 mm to the side of the centre of the pan of the tile and close to the bottom of the downturned flange.

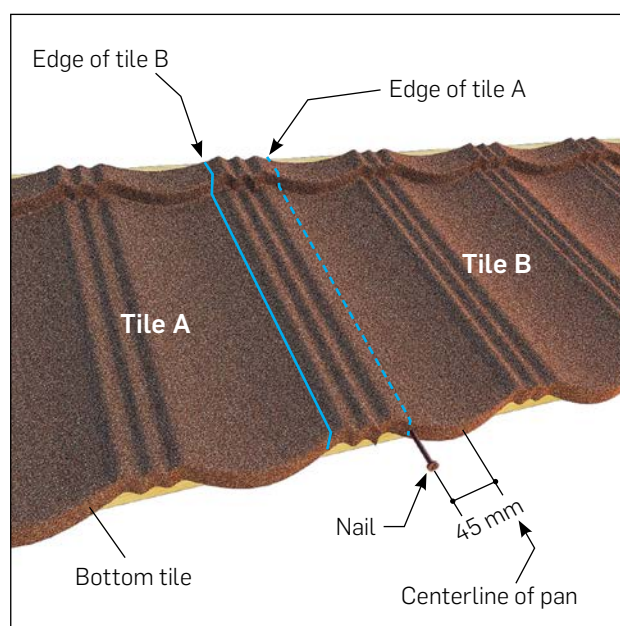
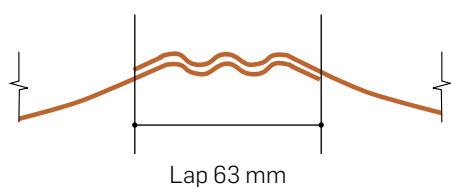
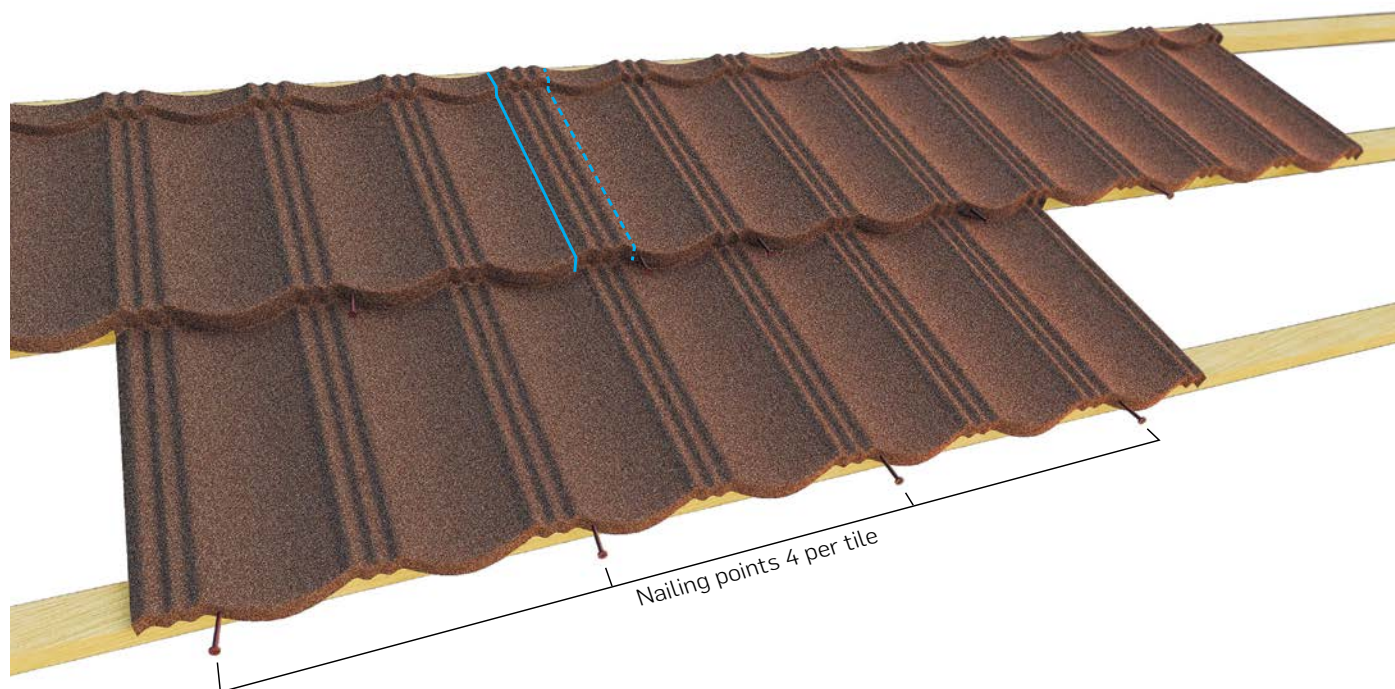

10 NAIL POSITIONING

CORONA SHAKE

Nails should be spaced approximately 300 mm apart. Care is required at the lap of the shake to ensure that the nail is placed outside of the hidden water channel.

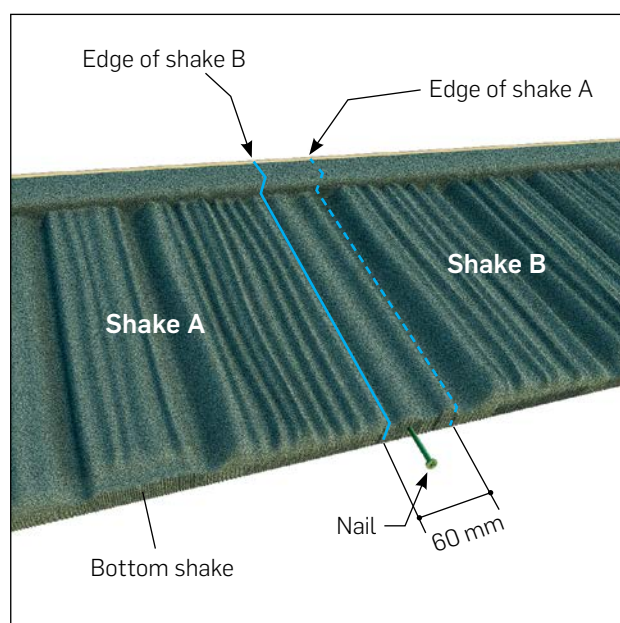
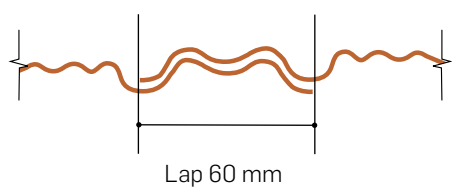
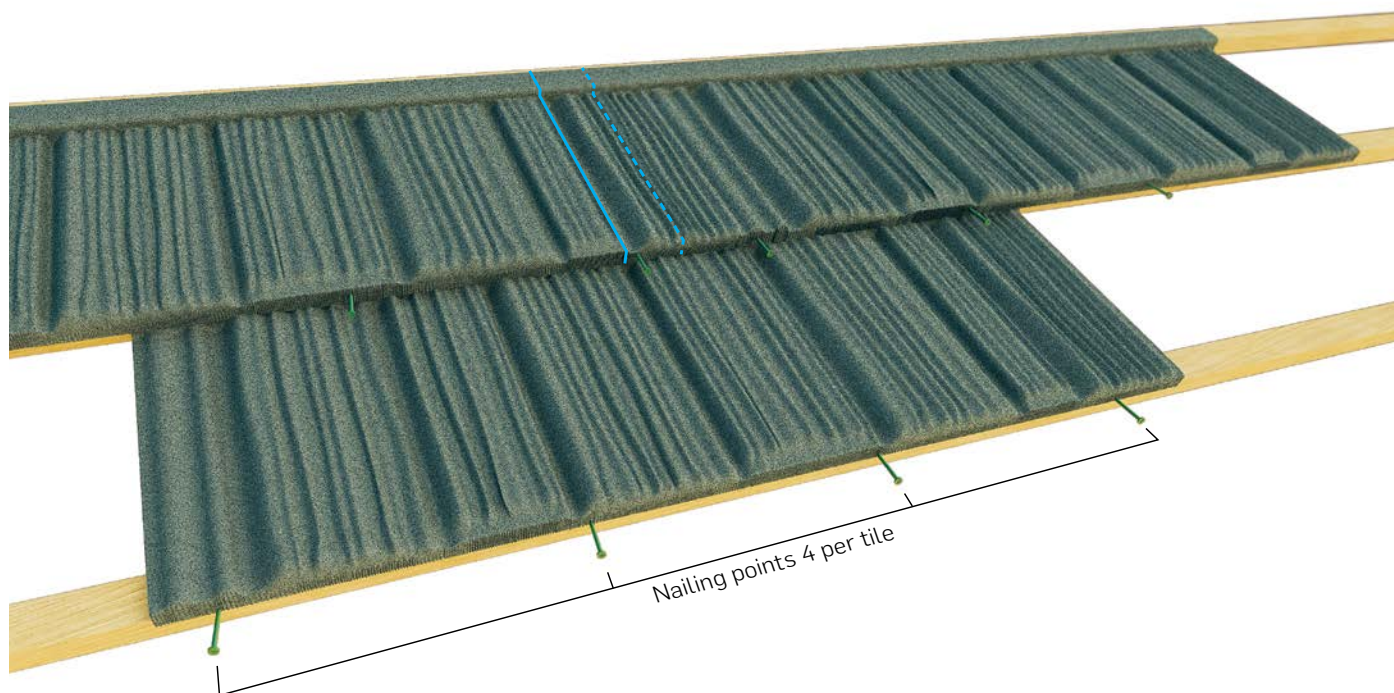

10 NAIL POSITIONING

SENATOR SHINGLE

Nails should be spaced approximately 300 mm apart. Care is required at the lap of the shingle to ensure that the nail is placed outside of the hidden water channel.

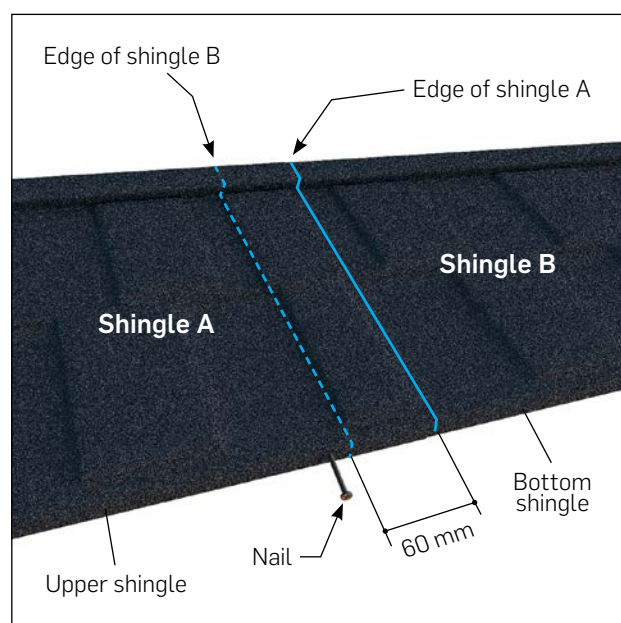
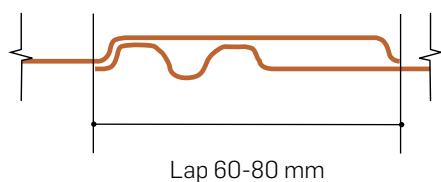
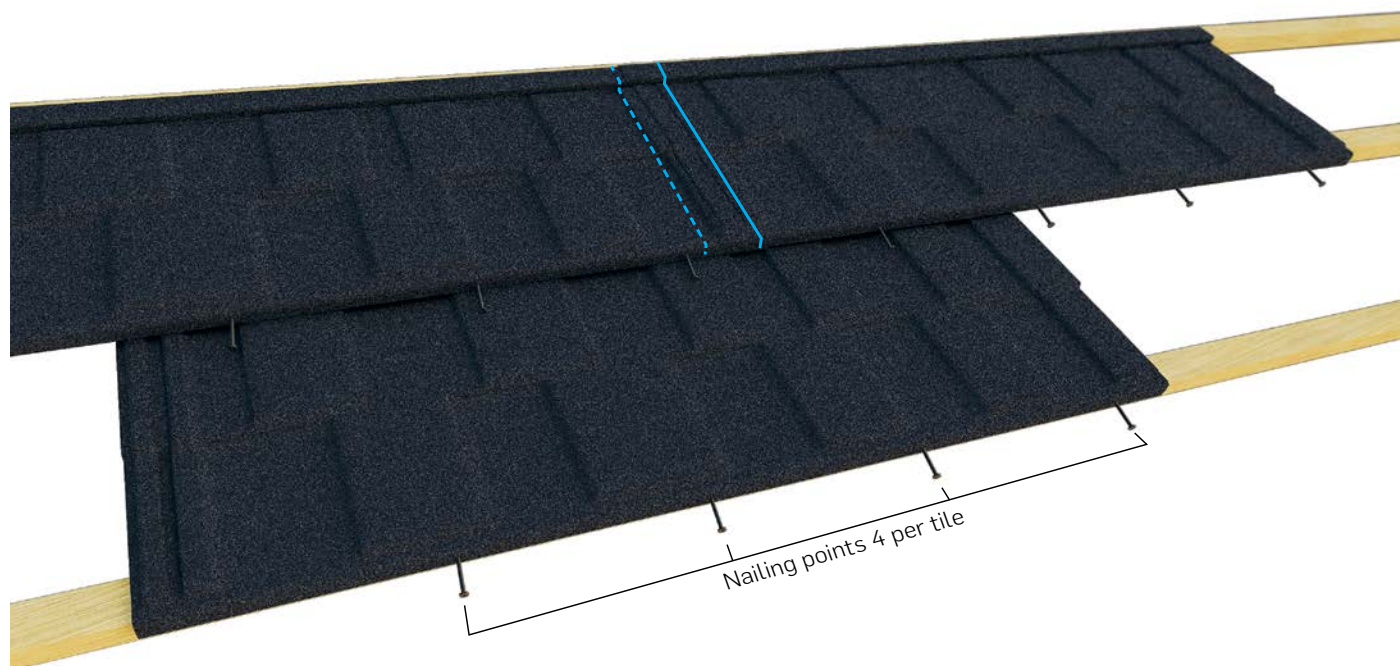

10 NAIL POSITIONING

MILANO TILES

Nails should be approximately 10 mm to the side of the section of tile that rises. Milano Tiles need to be nailed at the front and back of each tile where the tiles lap. Place weight on the nose of the tile being nailed so that the lap is held firmly down. Then place nails at every second module along nose of the tile.

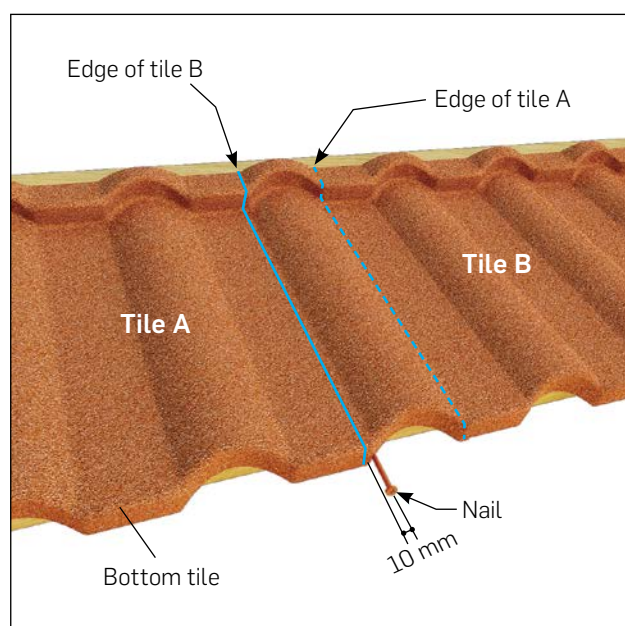
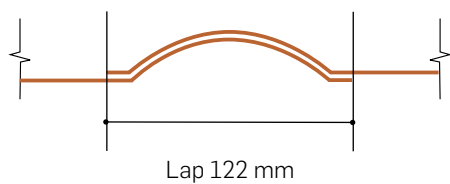
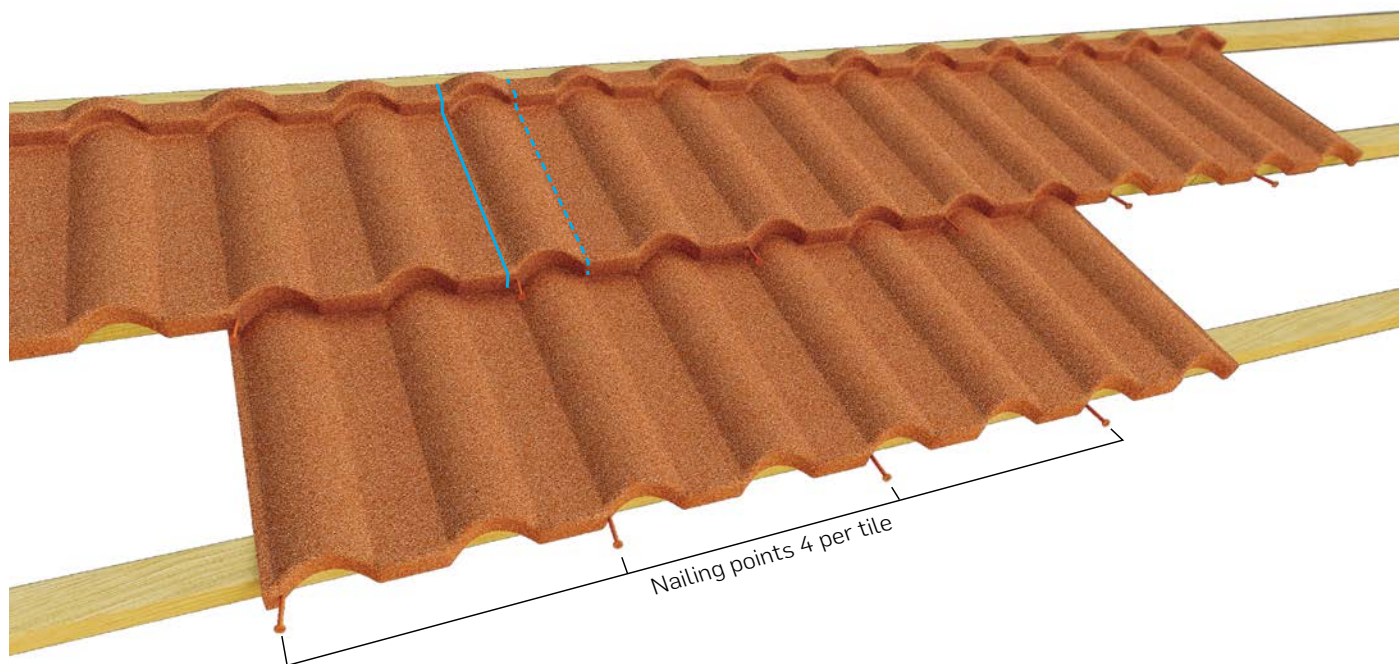

10 NAIL POSITIONING

ALPINE SLATE

Nails should be spaced approximately 300mm apart. Care is required at the lap of the Slates to ensure that the nail is placed outside of the hidden water channel and at the same time restricting nail penetration to a maximum of two thicknesses of Slate. Nailing where the profile is lowest will reduce the possibility of striking the top of the tile below.

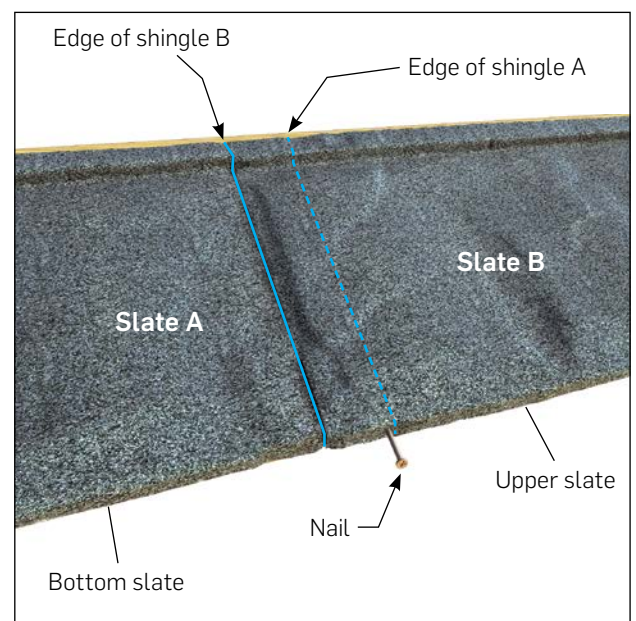
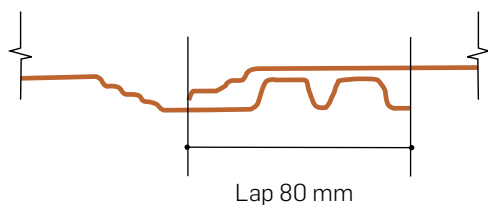
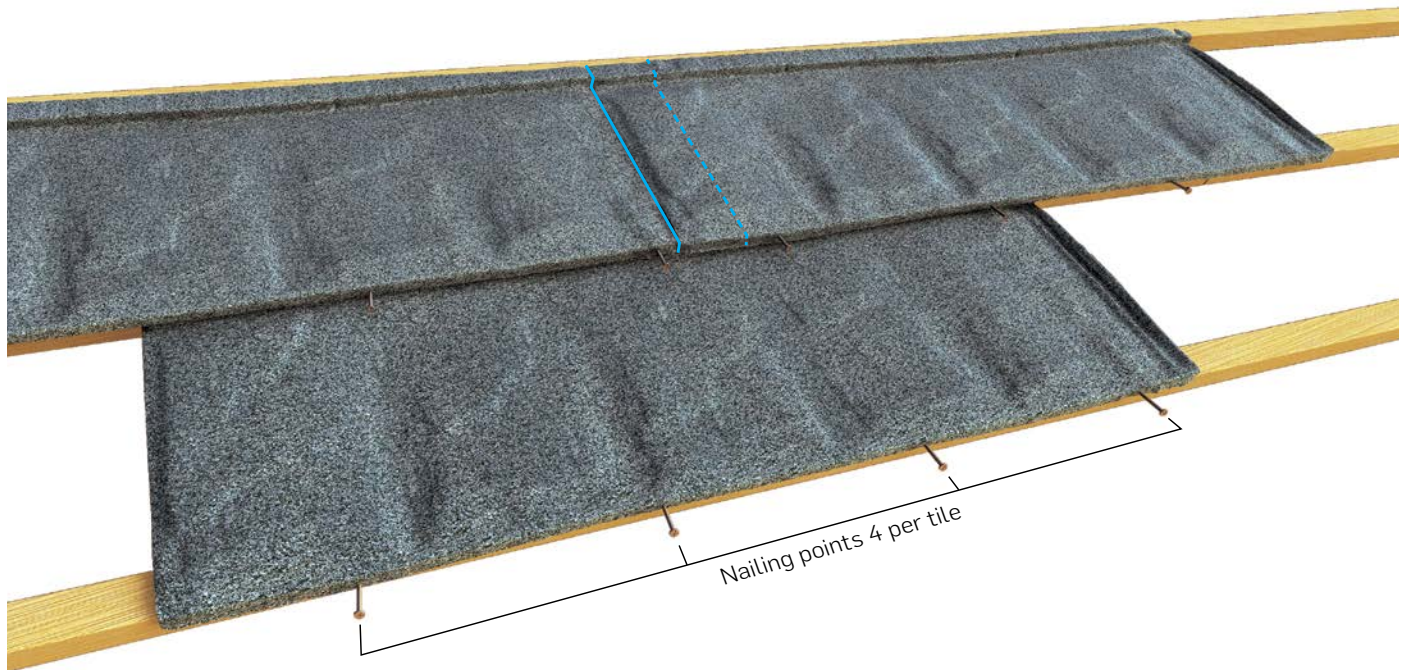

11 EAVES FLASHING

Construct the eave very carefully as it is an important part of the roof ventilation. An air intake opening should be provided, protected by a metal or plastic mesh (refer to page 10; **ROOF STRUCTURE/ Ventilation Space and page 13; BATTENS/ Eaves**).

1. PROTECTION FLASHING GOING BEHIND THE GUTTER

Nail the eaves flashing from the top into the first batten. Lay the first row of tiles (the last to be installed) and nail them at the nose of the tile and through the eaves flashing into the side of the first tile batten.

- 1 Tile
- 2 Tile Batten
- 3 Ventilation Space Batten
- 8 Underlay
- 11 Eaves Flashing
- 12 Mesh
- 13 Eaves Guard Flashing

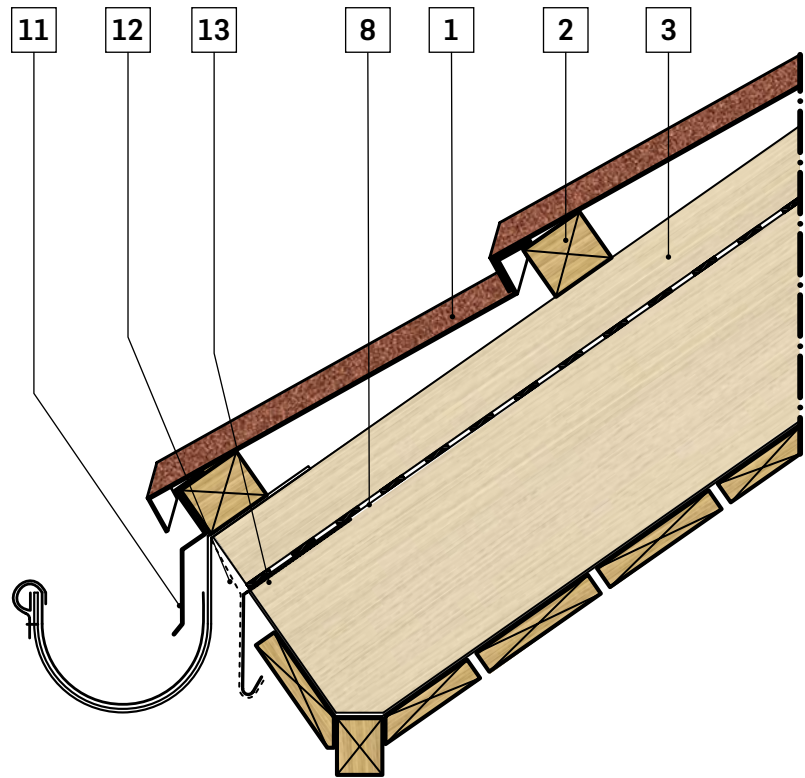

11 EAVES FLASHING

2. PROTECTION FLASHING GOING INTO THE GUTTER

Nail the eaves flashing from the top into the first batten. Lay the first row of tiles (the last to be installed) and nail them at the nose of the tile and through the eaves flashing into the side of the first tile batten.

- 1 Tile
- 2 Tile Batten
- 3 Ventilation Space Batten
- 8 Underlay
- 11 Eaves Flashing
- 12 Mesh
- 13 Eaves Guard Flashing

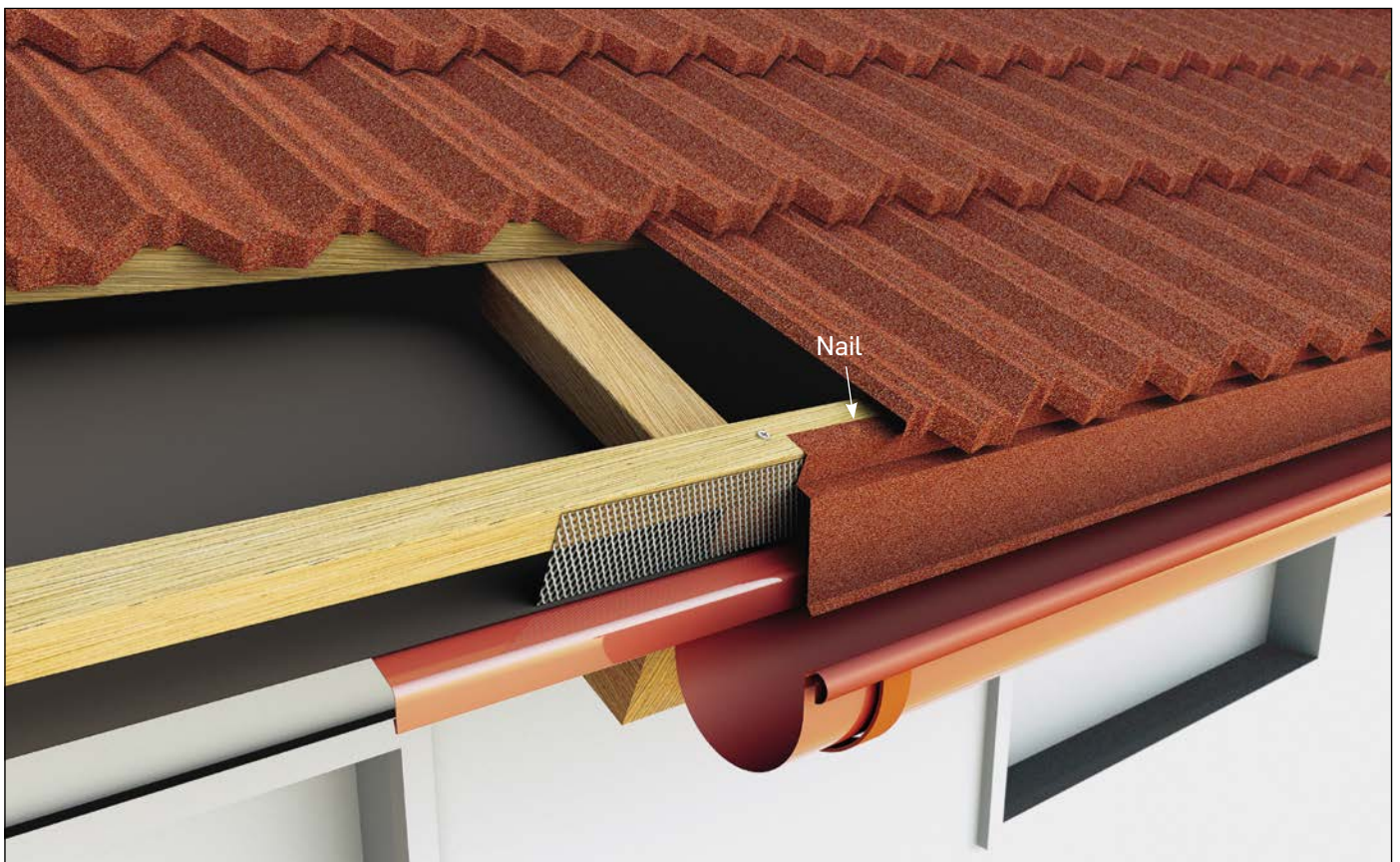
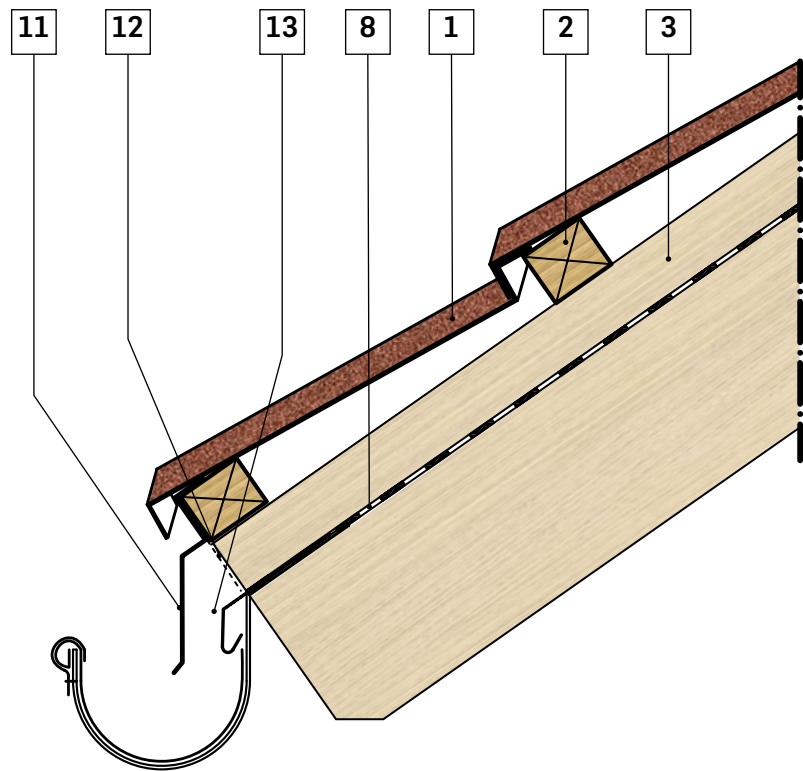

12 RIDGE

CUTTING AND BENDING TILES

Measure the distance (A) from the last tile to the spacers on the ridge batten (**refer to page 12; BATTENS/ Ridge Batten**). When installing the ridge without the use of spacers, the width of the air outlet must be deducted from the measurement. Add 40 mm to the measurement for a standard up-stand and mark the tile to be cut.

The height of the upstand can vary depending on the pitch of the roof.

A longer turn up on the last tile (at low pitches) facilitates fixing the tile into the ridge batten.

1. Place the full tile in the long tile bending attachment, which can be bolted to the bender. Line up the marks showing the bend line and bend the tile upwards. It is important to bend the tile first to avoid distortion when cutting.
2. Cut the tile along the marked cutting line using the guillotine, hand shears or metal cutting saw (**refer to page 4; IMPORTANT/ Cutting with a Saw**).
3. When making the gap for the air outlet without use of spacers (**refer to page 33; RIDGE/ Installation**), the upstand of the tile needs to be bent so that it makes a step.

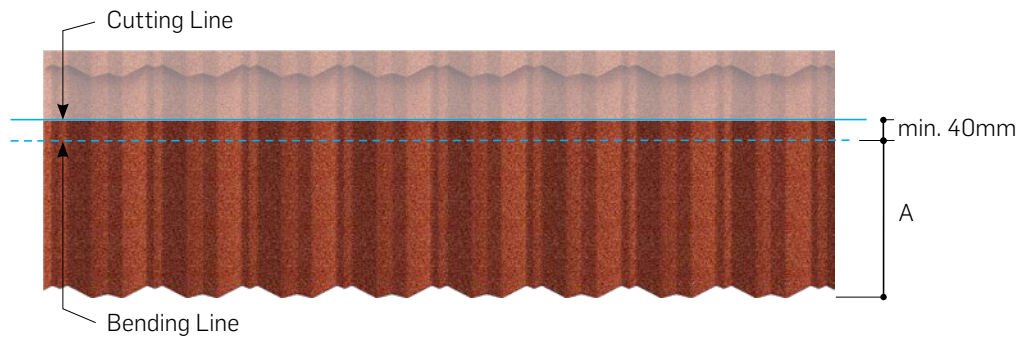

12 RIDGE

INSTALLATION

Install a thinner support batten at the ridge when the top course is less than the full width. This keeps the slope of the top tile width the same as the other tiles on the roof. The thickness of the support batten depends on the width of the top row tile. Fix all the cut tiles by nailing into the ridge batten in 4 places through the small bend on the turn up. This will leave space for ventilation (*refer to page 10; ROOF STRUCTURE/ Ventilation space*). An air outlet can also be ensured by installing spacers (*refer to page 12; BATTENS/ Ridge batten*). When installing the ridge using spacers, nail through the turn up and through the spacer.

The barrels are fixed from the top using screws or nails. The position of the fasteners should be at the ends of the barrels (at the overlap).

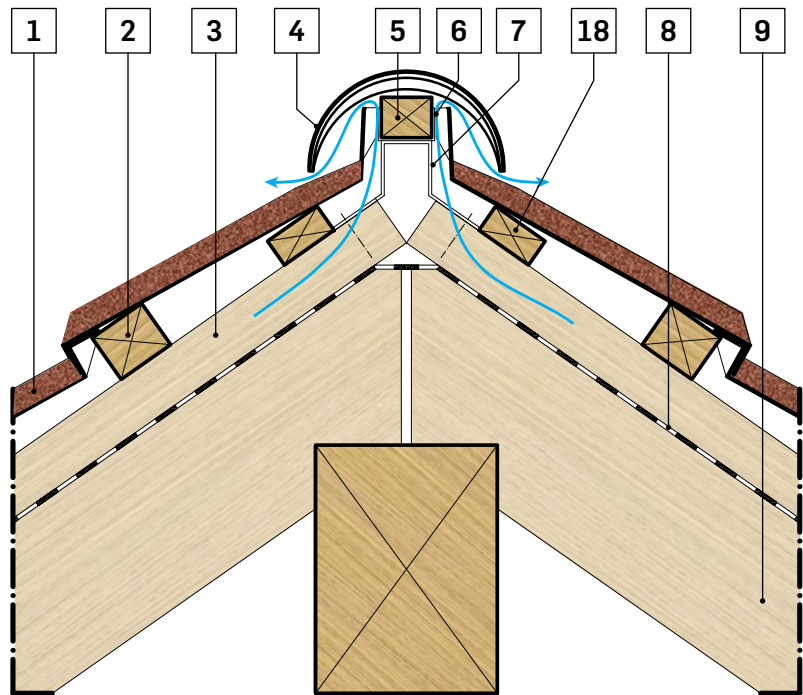

Intersection drawing of Option 1

- | | |
|----------------------------|---------------------------|
| 1 Tile | 8 Underlay |
| 2 Tile Batten | 9 Rafter |
| 3 Ventilation Space Batten | 18 Thinner Support Batten |
| 4 Barrel | |
| 5 Ridge Batten | |
| 6 Air Outlet | |
| 7 Ridge Bracket | |



Option 2: Ridge batten with spacers



Option 1: Ridge batten with air outlet

13 HIP

CUTTING AND BENDING TILES

The basic measurement is taken from the last corrugation of the bottom corner of the last tile, to the spacers on the hip tile batten. When installing the hip without the use of spacers, the width of the air outlet has to be deducted from the measurement.

Measure and mark the required measurements taken from the roof on the tiles with chalk or similar, ensuring that the matching corrugation of the overlapping tile to be cut is taken as the measurement starting point. This forms the Bending Line.

Add the height of the hip batten projection above the tile line to the bending line measurement to obtain the Cutting Line.

Each tile should supply two cut pieces, leaving minimal wastage.

Cut and bend the tiles according to the measurements determined above:

1. Flatten both up-stands of the tile where it is to be cut. This will make cutting easier.
2. Cut the tile along the marked Cutting Line using the guillotine, hand shears or metal cutting saw (**refer to page 4; IMPORTANT/ Cutting with a Saw**).
3. Bend the tile using a short tile bender.
4. When making a gap for the air outlet without the use of spacers (**refer to page 35; HIP/ Installation**), the upstand of the tile must be bent so that it makes a step.

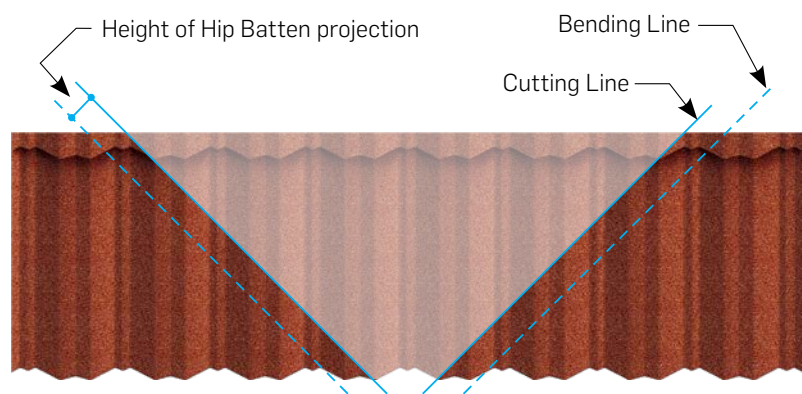
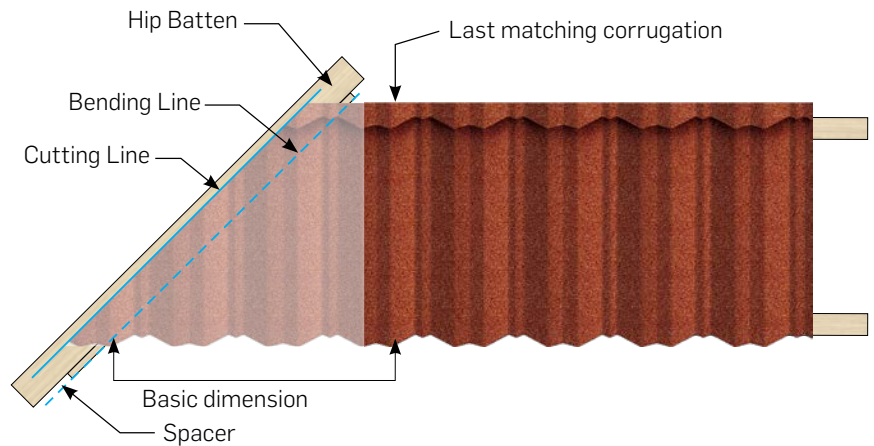

13 HIP

INSTALLATION

Fix all the cut tiles by nailing through the small bend on the turn up into the hip batten. This will leave a space for ventilation (*refer to page 10; ROOF STRUCTURE/ Ventilation space*). An air outlet can also be ensured by installing spacers (*refer to page 13; BATTENS/ Hip batten*). When installing the hip using spacers, nail through the turn up and through the spacer. Add one or more nails through the front edge into the tile batten, starting from the bottom course.

The barrels are fixed from the top using screws or nails into the hip batten. The position of the fasteners should be at the end of the barrel (at the overlap).

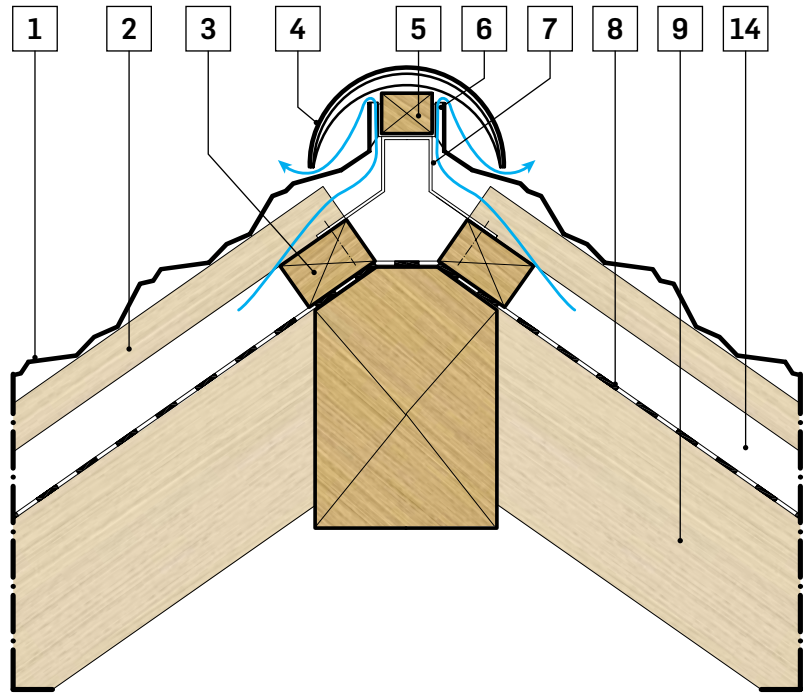

Intersection drawing of Option 1

- | | |
|----------------------------|----------------------|
| 1 Tile | 6 Air Outlet |
| 2 Tile Batten | 7 Hip Bracket |
| 3 Ventilation Space Batten | 8 Underlay |
| 4 Barrel | 9 Rafter |
| 5 Hip Batten | 14 Ventilation space |



Option 2: Hip batten with spacers



Option 1: Hip batten with air outlet

14 BOX BARGE

CUTTING AND BENDING TILES

Before the installation of the Box Barge, it is essential that the edge of the end tile is turned up against the barge batten (**refer to page 12; BATTENS/ Gable**). For measuring, cutting and bending the tiles, follow the same procedure as at the hips (**refer to page 34; HIP/ Cutting and Bending Tiles**).

Cut and bend the tiles according to the measurements:

1. Flatten both up stands of the tile where it is to be cut. This will make cutting easier.
2. Cut the tile along the marked cutting line using the guillotine, hand shears or metal cutting saw (**refer to page 4; IMPORTANT/ Cutting with a Saw**).
3. Bend the tile using a short tile bender.

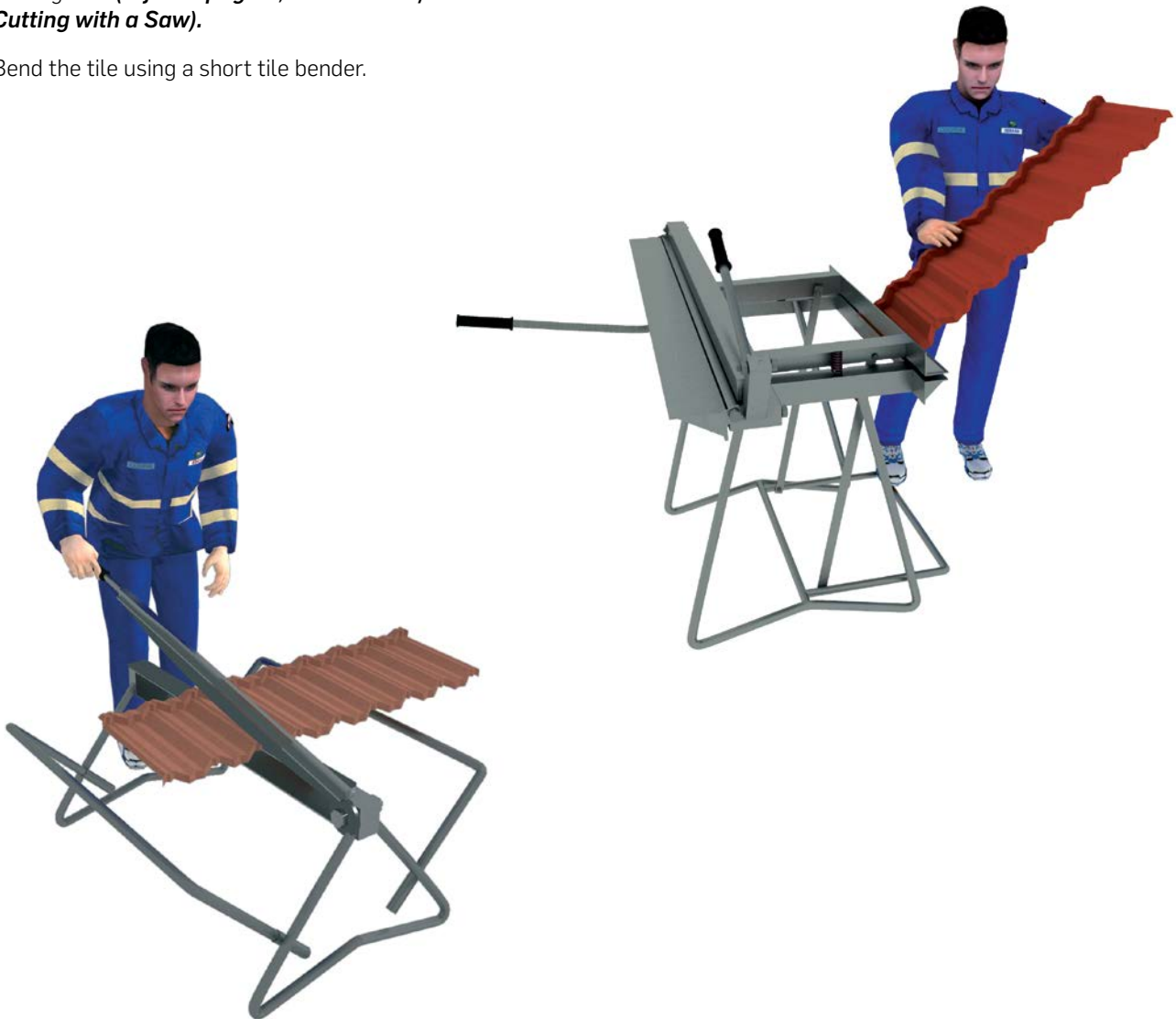
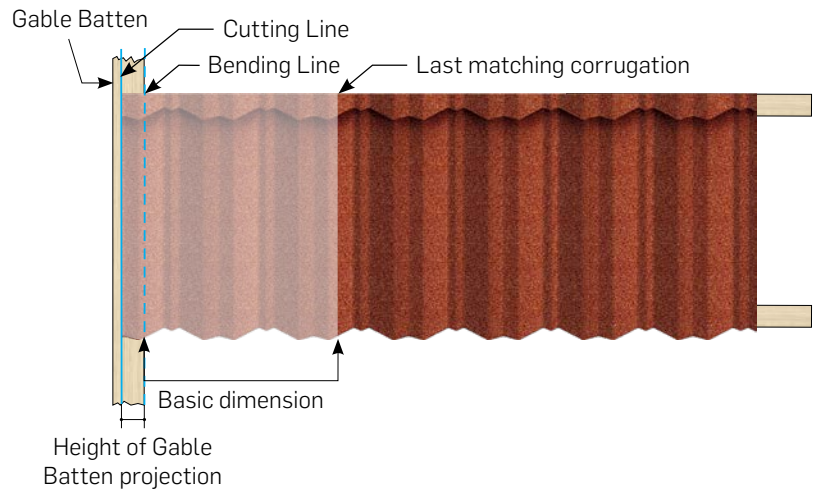

14 BOX BARGE

INSTALLATION

Tiles are cut, bent and fastened in place, nailing the turn up to the gable batten.

Begin by laying the Box Barges at the eave and temporarily tack the barge covers in place, working up the barge board. The overlap should be 100 mm.

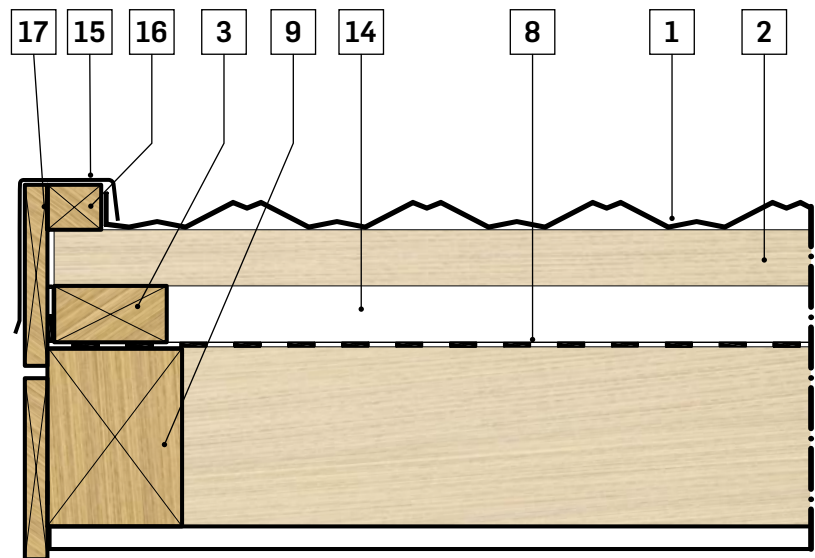

- | | | | |
|---|--------------------------|----|-------------------|
| 1 | Tile | 14 | Ventilation Space |
| 2 | Tile Batten | 15 | Box Barge |
| 3 | Ventilation Space Batten | 16 | Gable Batten |
| 8 | Underlay | 17 | Barge Board |
| 9 | Rafter | | |



Adjust the Box Barges in a straight line and fix them using nails or fasteners. Note that the fasteners need to be near the bottom edge of the Box Barge to ensure that the bottom edge is firmly positioned against the barge board.



14 BOX BARGE

BOX BARGE END

1. Mark the required measurements (indicated by the blue lines) on the Box Barge (*Step 1*). These measurements are universal to all roof pitches.
2. Cut the Box Barge along the Cutting line (solid blue line) using hand shears. Using right and left handed shears can make cutting easier (*Step 2*).
3. Bend the Box Barge along the Bending line (dotted blue line) (*Step 3 to Step 5*).

Step 1: Left view

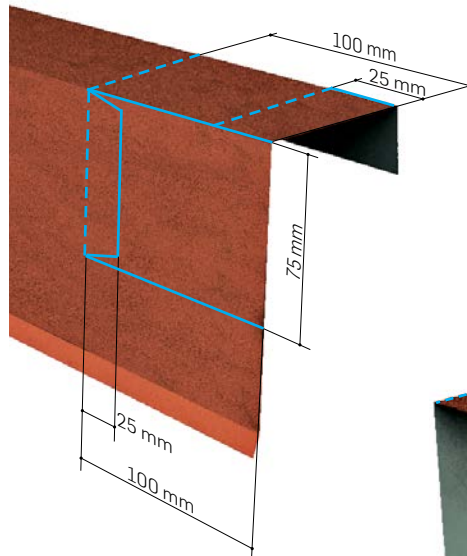

Step 1: Right view

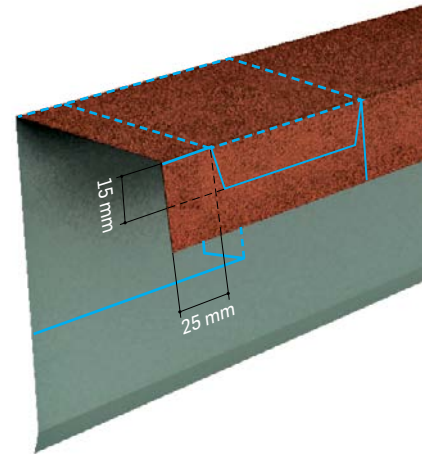

Step 2: Left view

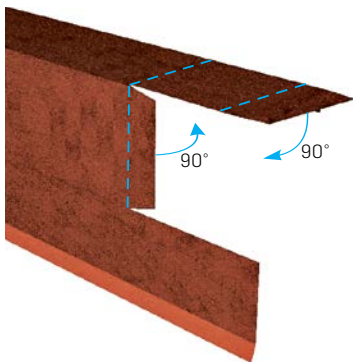

Step 3: Left view

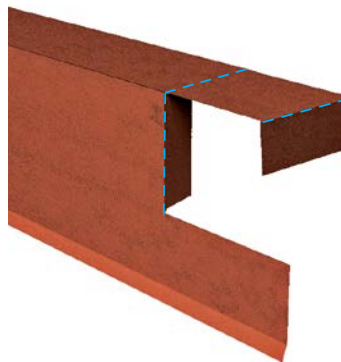

Step 4



Step 2: Right view

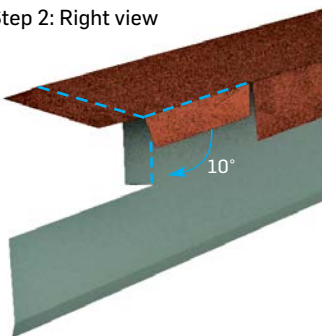

Step 3: Right view

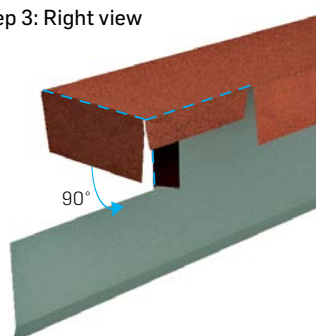

Step 5



14 BOX BARGE

OPTION 1:

The nose of the tile at the junction with the barge batten is close to the eaves batten (first batten).

1. Place the Box Barge End in its final position and mark the bending line against the Eaves Flashing (*Step 1*).
2. Add 15 mm to the bending line and draw the cutting line (*Step 1*).
3. Cut and bend the Box Barge End into its final shape (*Step 2, Step 3*).
4. Place the Box Barge End in its final position (*Step 4*).

Option 1: Step 1

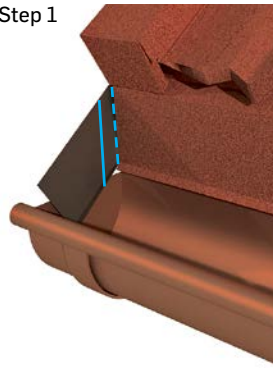

Option 1: Step 2

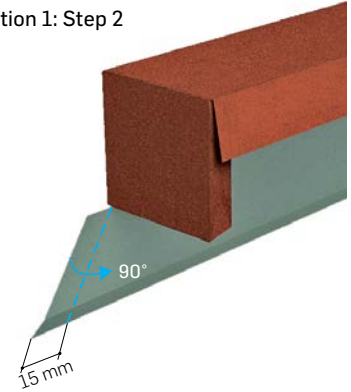

Option 1: Step 3

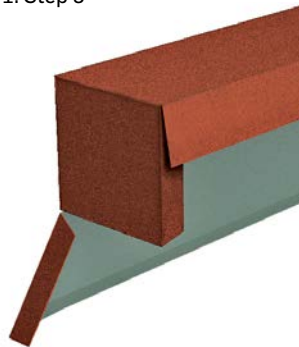

Option 1: Step 4



OPTION 2:

The nose of the tile at the junction with the barge batten is not close to the eaves batten.

1. Place the Box Barge End on top of the tile, mark the cutting line from the nose of the tile and cut the Box Barge End along the cutting line (*Step 1*).
2. Place the Box Barge End in its final position and mark the bending line against the Eaves Flashing (*Step 2*).
3. Add 15 mm to the bending line and draw the cutting line (*Step 2*).
4. Cut and bend the Box Barge End into its final shape (*Step 3, Step 4*).
5. Place the Box Barge End in its final position (*Step 5*).

Option 2: Step 1

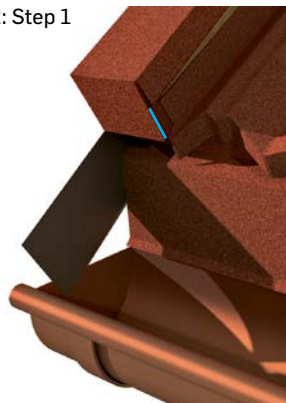

Option 2: Step 2

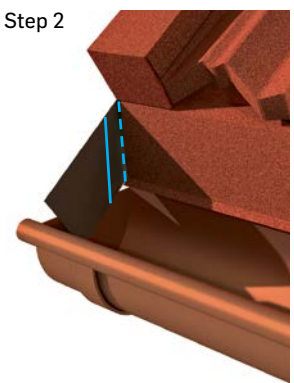

Option 2: Step 3

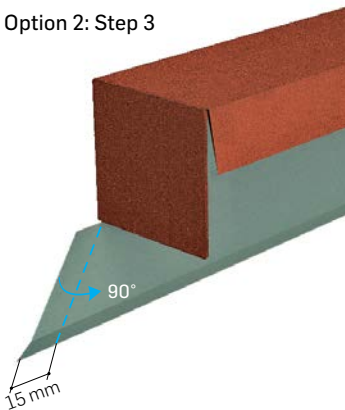

Option 2: Step 4



Option 2: Step 5



15 SCRIBED BOX BARGE

INSTALLATION

Tiles are cut, bent and fastened in place, with the turn up nailed to the gable batten.

Begin laying the scribed box barges at the eaves, adjusting the first (lowest) notch to the bottom tile at the barge. Temporarily tack the barge covers in place, working up the barge board. The overlap is provided by the notched shape of the scribed box barge.

Adjust the scribed box barges in a straight line and secure them using screws.

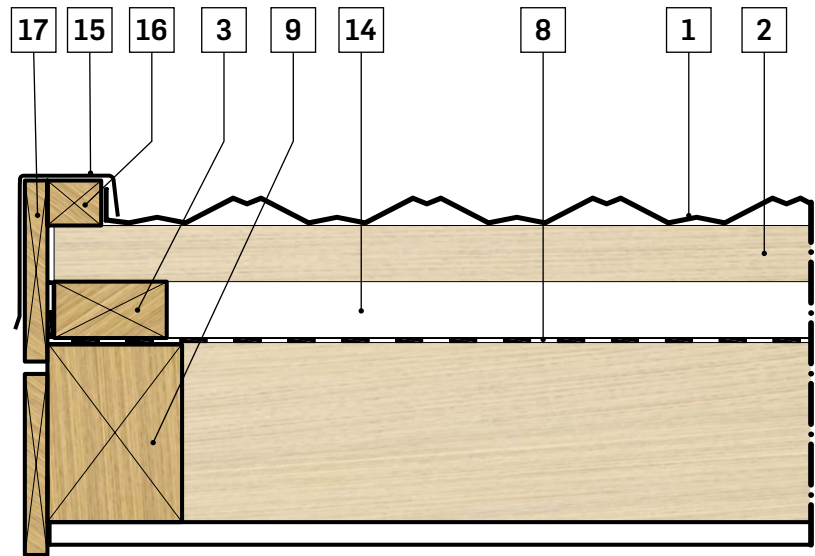

- | | | | |
|---|--------------------------|----|-------------------|
| 1 | Tile | 14 | Ventilation Space |
| 2 | Tile Batten | 15 | Scribed Box Barge |
| 3 | Ventilation Space Batten | 16 | Gable Batten |
| 8 | Underlay | 17 | Barge Board |
| 9 | Rafter | | |



16 RIDGE - SINGLE SLOPED ROOF

INSTALLATION

Install the top barge board. Fix it onto the counter batten and rafter. Install a thinner support batten at the ridge when the top course is less than the full width. For measuring, cutting and bending tiles, follow the same procedure as the ridge (*refer to page 32; RIDGE/ Cutting and Bending Tiles*). To provide an air outlet ensure there is a gap between the barge board and the upstand of the top tile. Spacers (pieces of wood) can be installed.

Barge flashing made from GERARD Flat Sheet can be used instead of Box Barge. Adjust the Box Barges in a straight line and fix them onto the barge board using nails or fasteners.

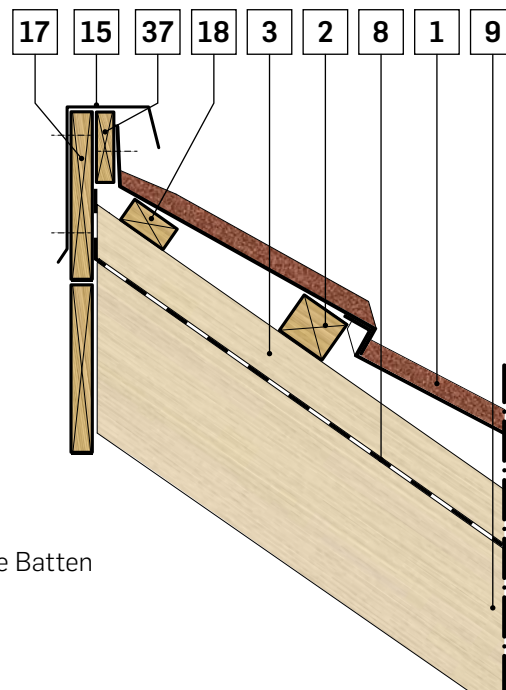

- 1 Tile
- 2 Tile Batten
- 3 Ventilation Space Batten
- 8 Underlay
- 9 Rafter
- 15 Box Barge
- 17 Barge Board
- 18 Thinner Support Batten
- 37 Spacer



17 WALL FLASHING

Great care is needed where the roof surface joins a vertical wall. It is essential to bend the ends of the tiles under the flashing. For measuring, cutting and bending, the tiles follow the same procedure as the Box Barges (*refer to page 36; BOX BARGE/ Cutting and Bending Tiles*).

1. WALL FLASHING AT A JUNCTION WITH FINISHED FACADE

Where the roof surface joins a finished facade, use a custom made flashing that will allow the junction of the flashing and the render to be sealed with a sealant. It is also possible to bend the top edge of the side flashing. In this case, there is no need to use additional custom made flashing.

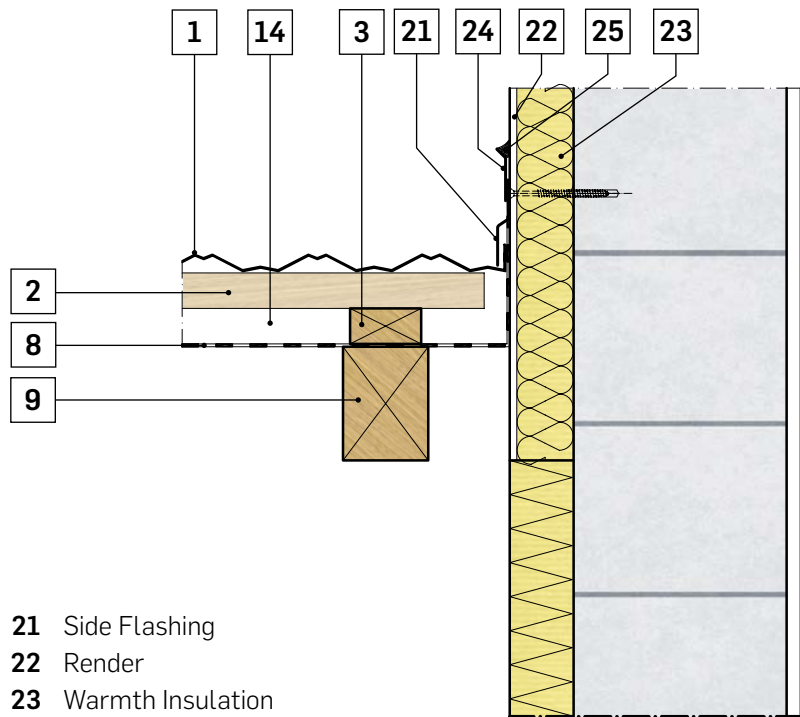

- | | | | |
|----|--------------------------|----|----------------------------|
| 1 | Tile | 21 | Side Flashing |
| 2 | Tile Batten | 22 | Render |
| 3 | Ventilation Space Batten | 23 | Warmth Insulation |
| 8 | Underlay | 24 | Purpose Made Side Flashing |
| 9 | Rafter | 25 | Sealant |
| 14 | Ventilation Space | | |

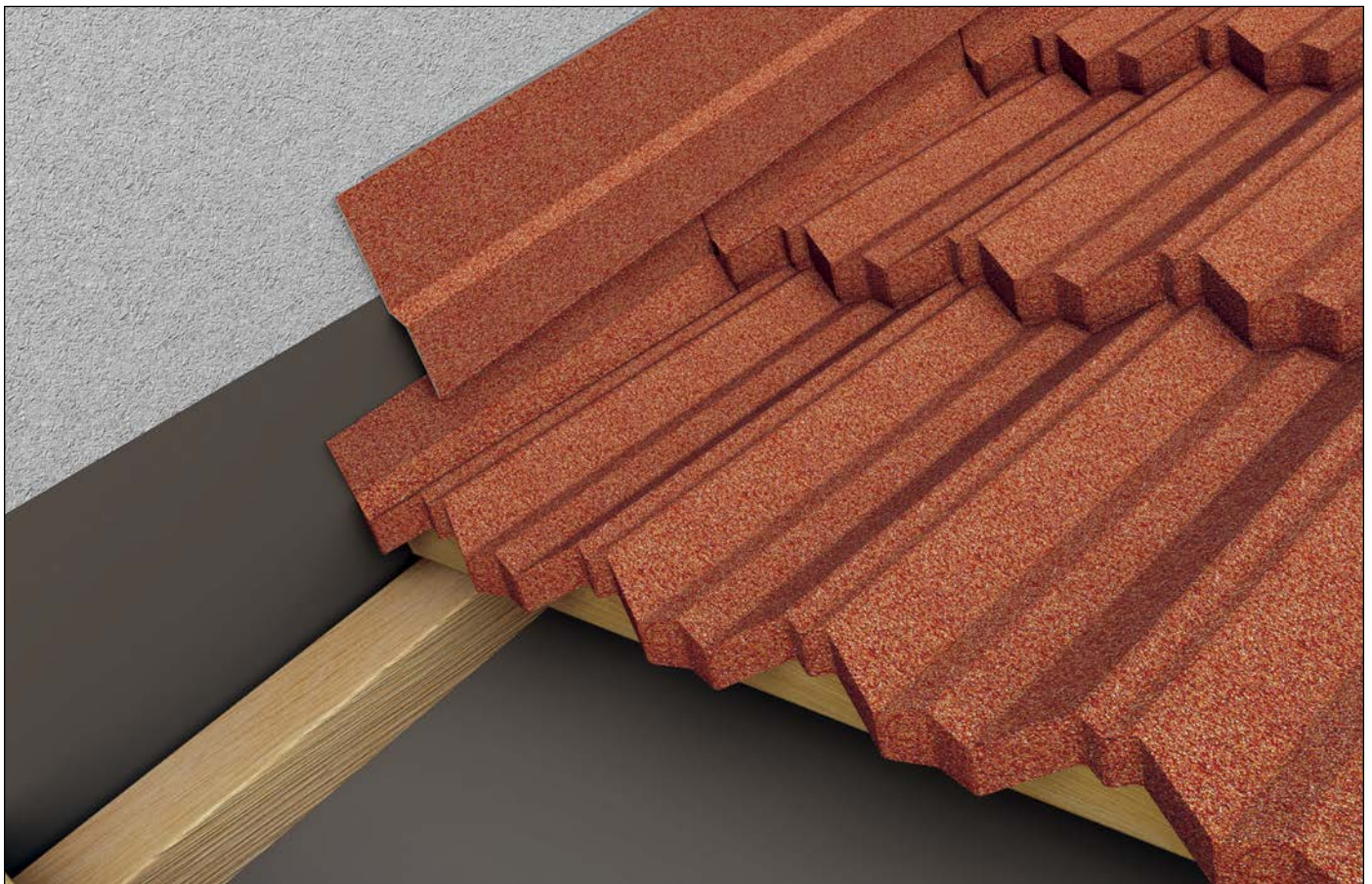

17 WALL FLASHING

2. WALL FLASHING AT A JUNCTION WITH AN UNFINISHED FACADE

If the facade is not finished, leave a part of the roof near to the facade uncovered. Install a purpose made flashing on the bottom end of the facade and make the facade before finalising the roof covering. Use sealant on the junction of the render and the Side Wall Starter Flashing.

Do not nail the tile to the wall. Fix the side flashing to the wall ensuring that it is firmly in place and straight.

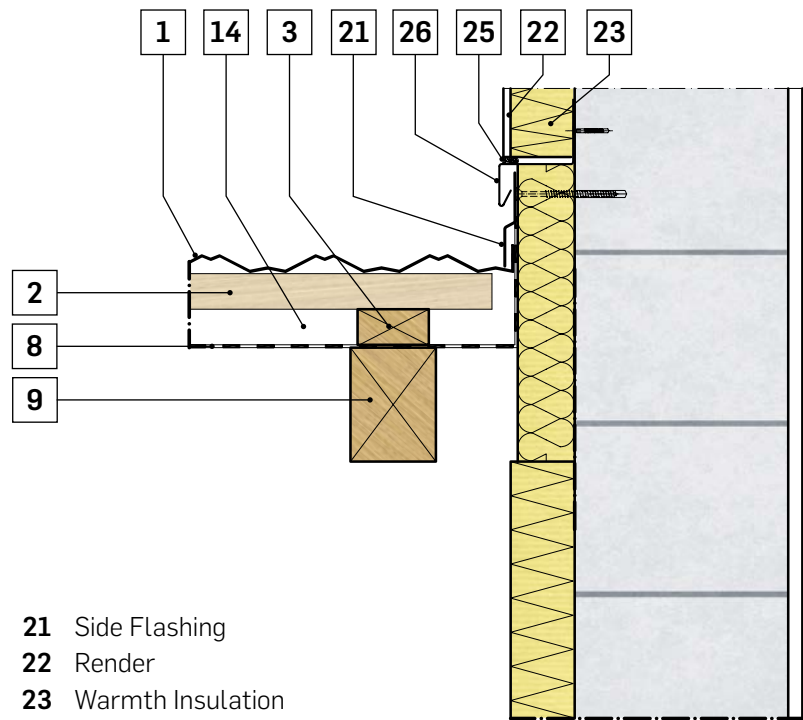

- | | | | |
|----|--------------------------|----|----------------------------|
| 1 | Tile | 21 | Side Flashing |
| 2 | Tile Batten | 22 | Render |
| 3 | Ventilation Space Batten | 23 | Warmth Insulation |
| 8 | Underlay | 25 | Sealant |
| 9 | Rafter | 26 | Side Wall Starter Flashing |
| 14 | Ventilation Space | | |

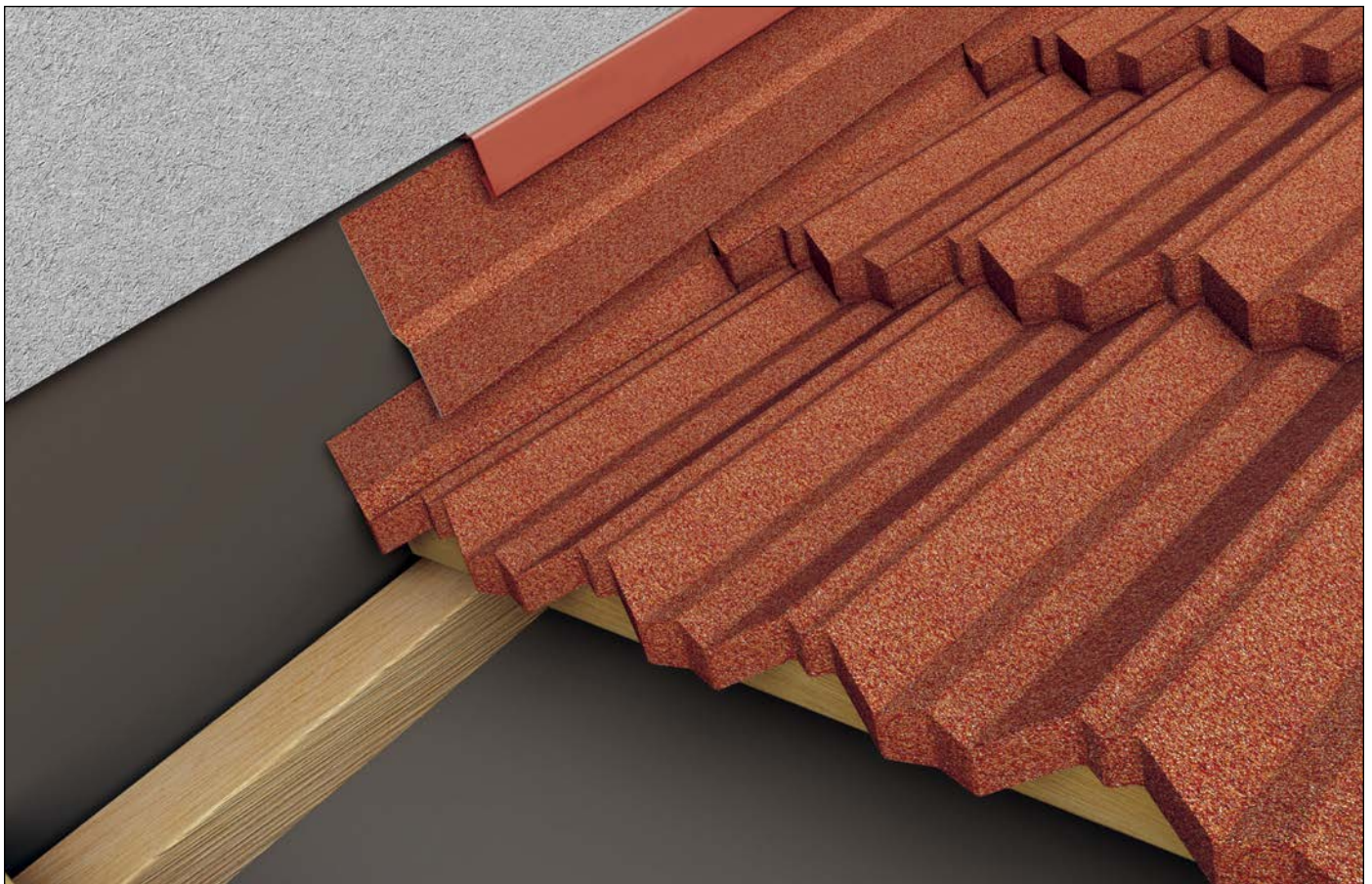

18 TOP WALL FLASHING

Where the roof/wall junction runs horizontally, the principles of ventilation are the same as at a ridge. It is essential to bend the ends of tiles under the flashing (*refer to page 32; RIDGE/Cutting and Bending Tiles*).

Install a thinner support batten at the ridge when the top course is less than the full width (*refer to page 33; RIDGE/Installation*).

For measuring, cutting and bending tiles, follow the same procedure as the ridges (*refer to page 32; RIDGE/ Cutting and Bending Tiles*).

If the facade is not finished, leave a part of the roof near the facade uncovered. Install a purpose made flashing on the bottom end of the facade and make the facade before finalising the roof coverage. Use sealant on the junction of the render and the Top Wall Starter Flashing.

Where the roof surface joins finished facade, use a custom made flashing that will allow the junction between the flashing and the render to be sealed with a sealant (*refer to page 43; WALL FLASHING*).

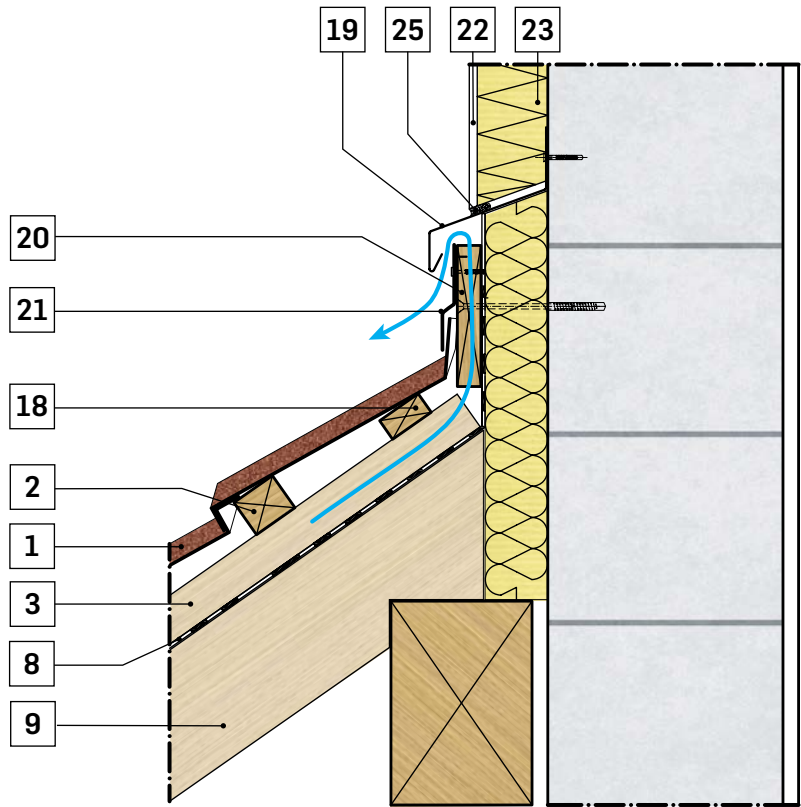

- 1 Tile
- 2 Tile Batten
- 3 Ventilation Space Batten
- 8 Underlay
- 9 Rafter
- 18 Support Batten
- 19 Top Wall Starter Flashing
- 20 Top Wall Spacer
- 21 Side Flashing
- 22 Render
- 23 Warmth Insulation
- 25 Sealant



19 MILANO RIDGE WALL FLASHING

INSTALLATION

Install a thinner support batten at the ridge when the top course is less than the full width (**refer to page 31; RIDGE/ Installation**). Cut tile approximately 30 mm from the ridge batten. The flat on the back of the tile then needs to be turned up approximately 25 mm. This brings the tile shape back to its shaped profile and provides a barrier against any wind-driven rain. Install Milano Ridge Wall Flashing. The flashing is fixed from the top into the top course tile using screws and by nailing through the small bend on the turn up into the ridge batten. When installing the ridge using spacers, nail through the turn up and through the spacer (**refer to page 33; RIDGE/ Installation**). The barrels are fixed from the top using screws or nails.

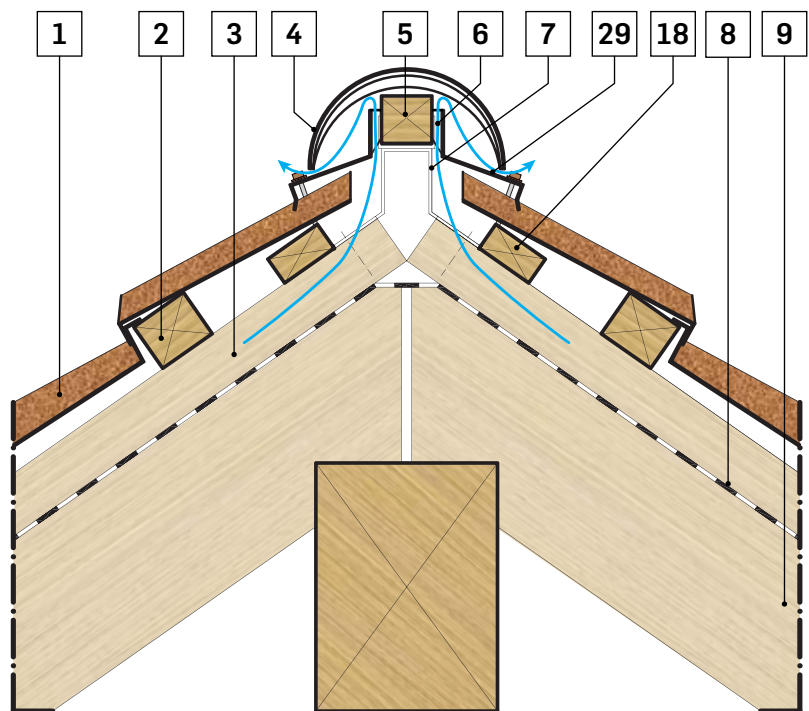

- | | |
|----------------------------|-------------------------------|
| 1 Tile | 7 Ridge Bracket |
| 2 Tile Batten | 8 Underlay |
| 3 Ventilation Space Batten | 9 Rafter |
| 4 Barrel | 18 Thinner Support Batten |
| 5 Ridge Batten | 29 Milano Ridge Wall Flashing |
| 6 Air Outlet Opening | |

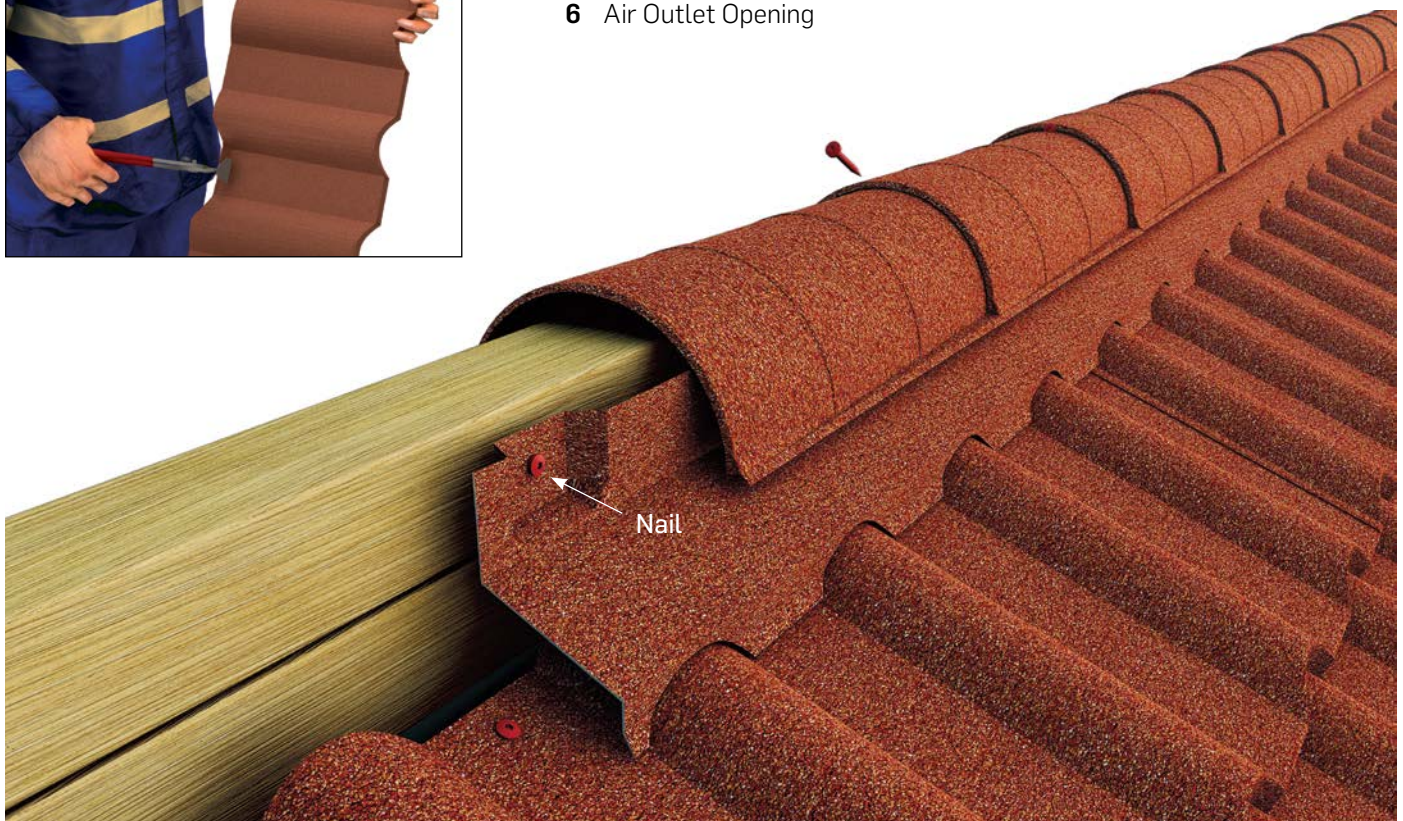

CUTTING AND BENDING TILES

The basic measurement is taken from the last corrugation of the bottom corner of the last tile, to the end of the tile battens along the front edge of the batten. Allow for tolerance in fit when measuring.

Measure and mark the tile with the measurements taken from the roof ensuring the matching corrugation of the overlapping tile to be cut is taken as the measure starting point. This forms the Bending Line.

Add 40 mm to the Bending Line on the back edge of the tile and 50 mm to the Bending Line on the nose of the tile to obtain the Cutting Line.

Each tile should supply two cut pieces leaving minimal wastage.

Cut and bend the tiles according to the measurements determined above.

1. Flattening both up-stands of the tile where the tile is to be cut will make cutting easier.
2. Cut the tile along the marked cutting line using the guillotine, hand shears or metal cutting saw (**refer to page 4; IMPORTANT/ Cutting with a Saw**).
3. Bend the tile using a short tile bender.

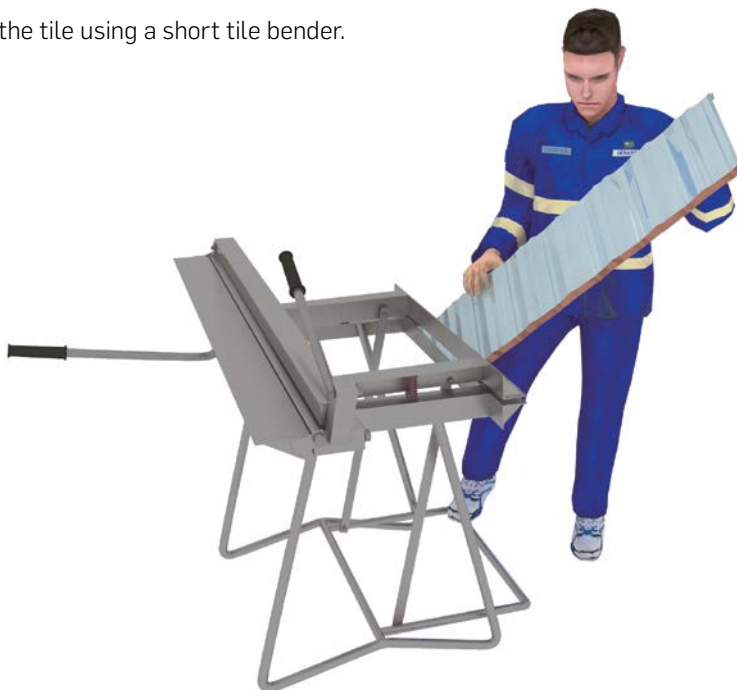
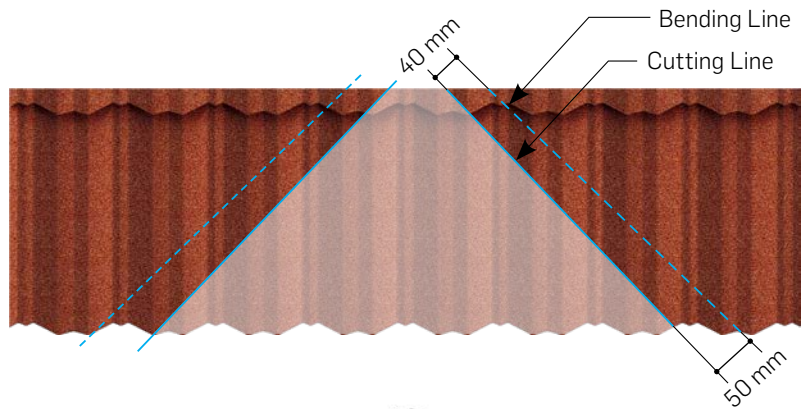

20 VALLEY

INSTALLATION

Cut and bend the tiles at the Valley as straight as possible to obtain a straight line. The last tile should be nailed into the tile batten as close to the batten end as practicable. Never nail into the Valley gutter.

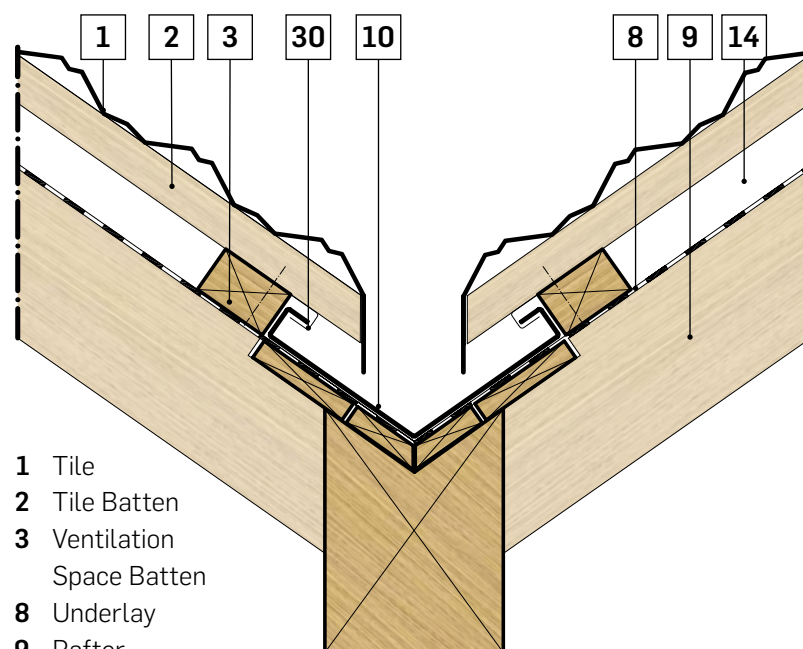

- 1 Tile
- 2 Tile Batten
- 3 Ventilation Space Batten
- 8 Underlay
- 9 Rafter
- 10 Valley
- 14 Ventilation Space
- 30 Clip



21 CHIMNEY FLASHING

OPTION 1:

The Chimney Flashing may be installed as per traditional roofing practice, using aluminium or zinc coated flashings. It is made in 4 parts: front, back and left and right sides.

It is essential to adequately prepare the supports for all parts of the chimney. The back should rest on a board of approx. 2 cm thickness. The ends of the tile battens on both sides of the chimney should be notched approx. 2 cm so that the left and the right sides of the flashing form a good fit.

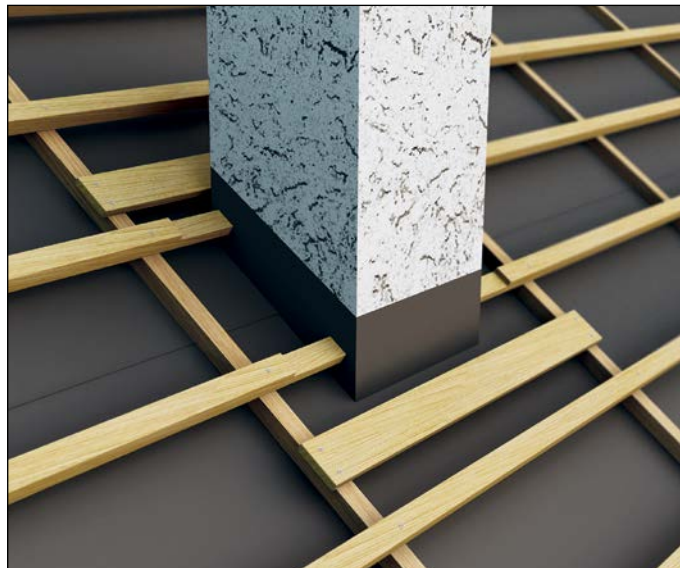
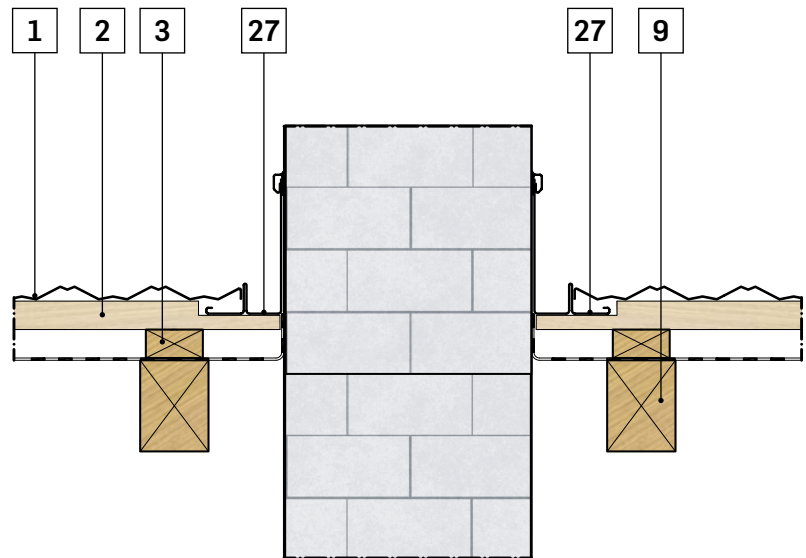

- 1 Tile
- 2 Tile Batten
- 3 Ventilation Space Batten
- 9 Rafter
- 27 Chimney Flashing

The front of the chimney flashing should rest on the first row of tiles under the chimney. Bend the tiles down along the upper stand of the side flashings.

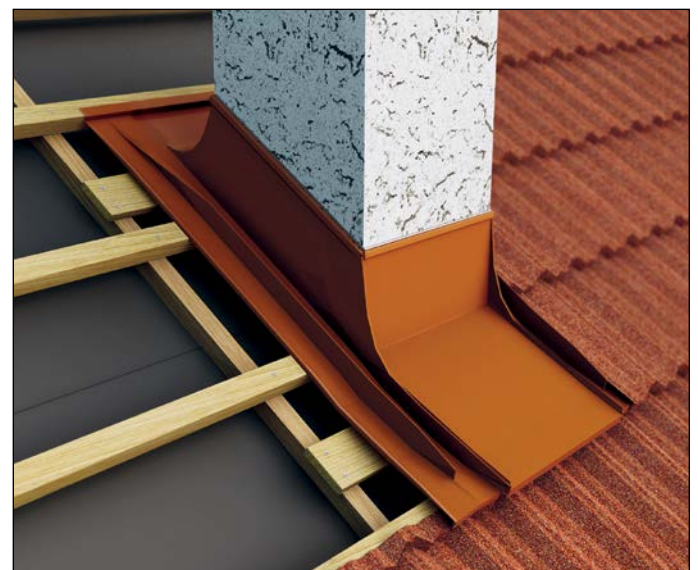
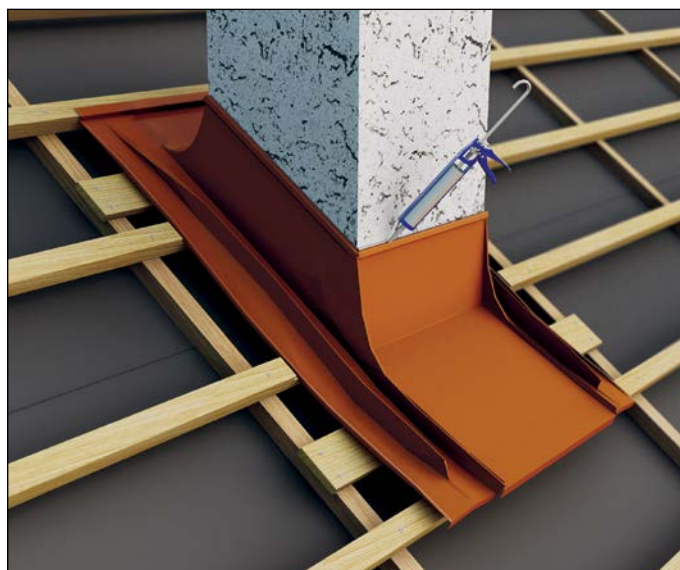

21 CHIMNEY FLASHING

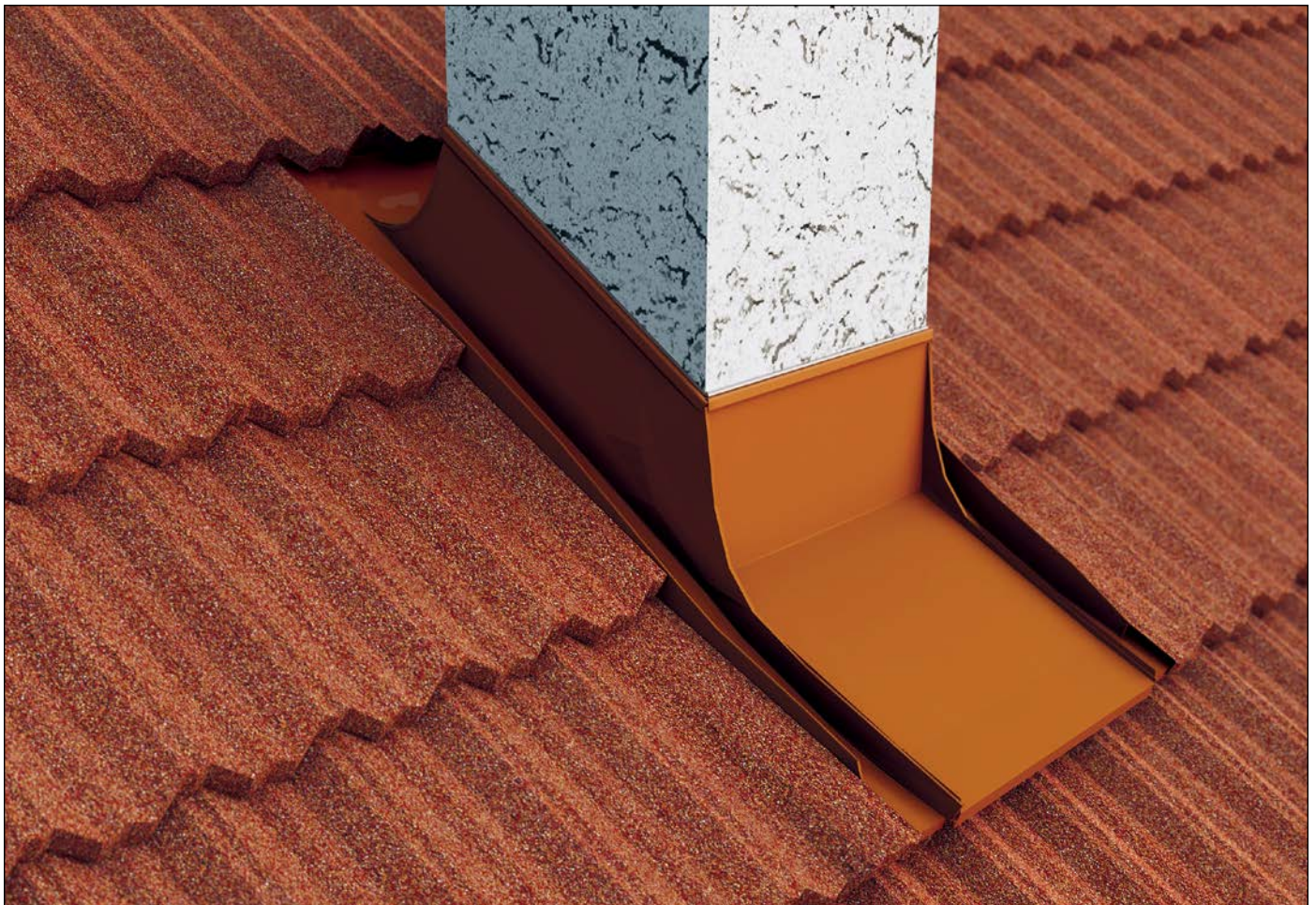
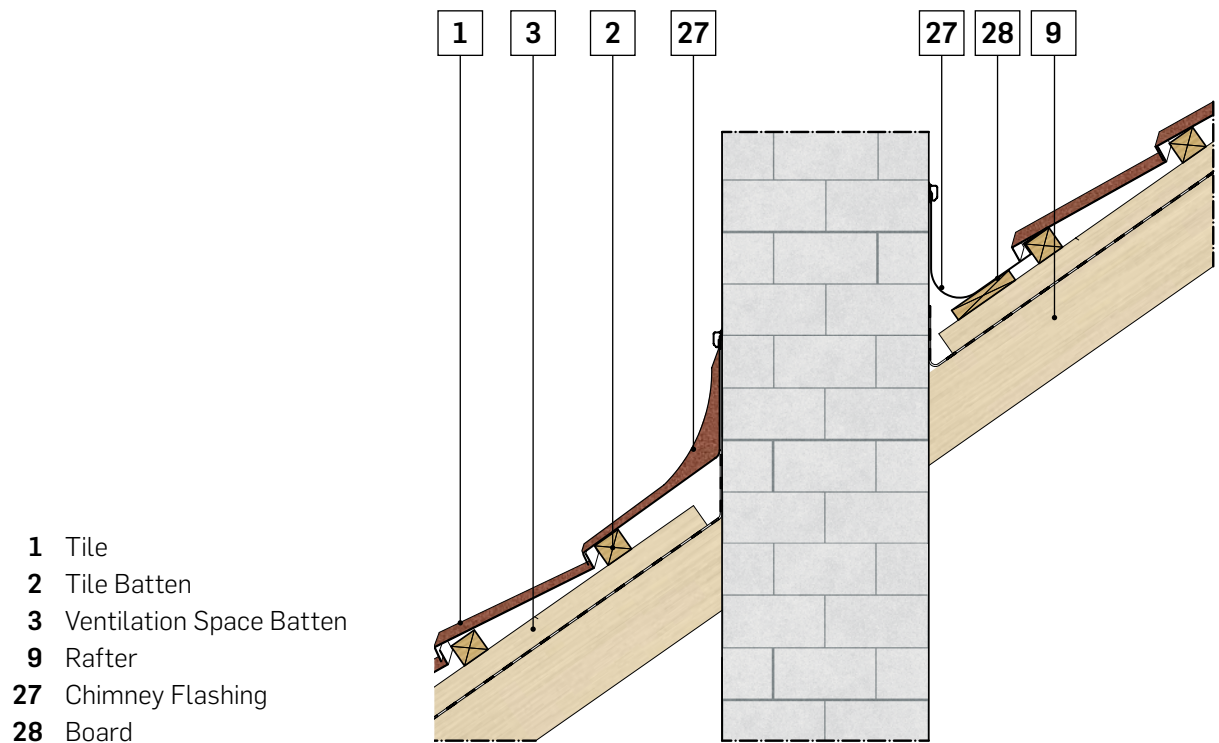

21 CHIMNEY FLASHING

OPTION 2:

Chimney flashings are produced from flat sheets coated with Gerard stone chips. Consisting of 4 parts – front, back and two sides – they are individually manufactured, taking into account the dimensions of the chimney and the distance from the nearest full tile row. Tiles are turned upwards 5cm against the chimney and a 2cm wide wooden board is used as a support at the front and the back of the chimney.

The front of the chimney flashing is placed on the nearest full tile row below the chimney. The sides of the chimney flashing are joined to the front and back parts by a single standing and flat lock seam.

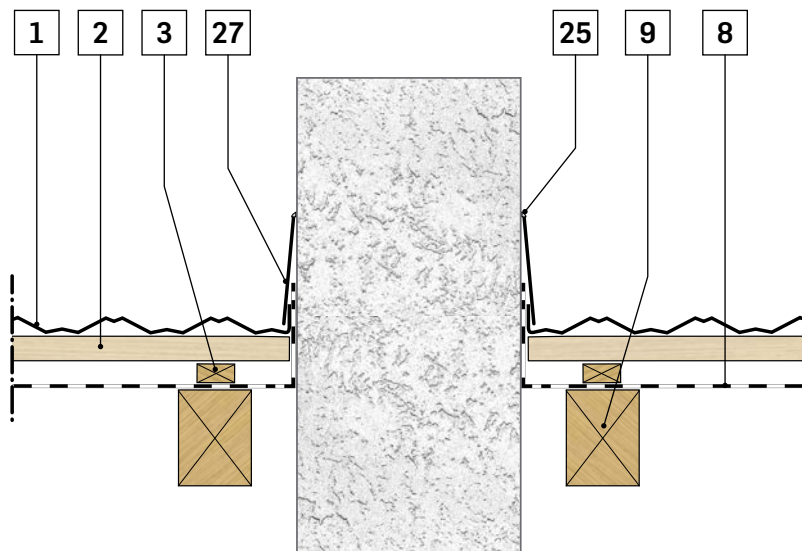

- 1 Tile
- 2 Tile Batten
- 3 Ventilation Space Batten
- 8 Underlay
- 9 Rafter
- 25 Sealant
- 27 Chimney Flashing

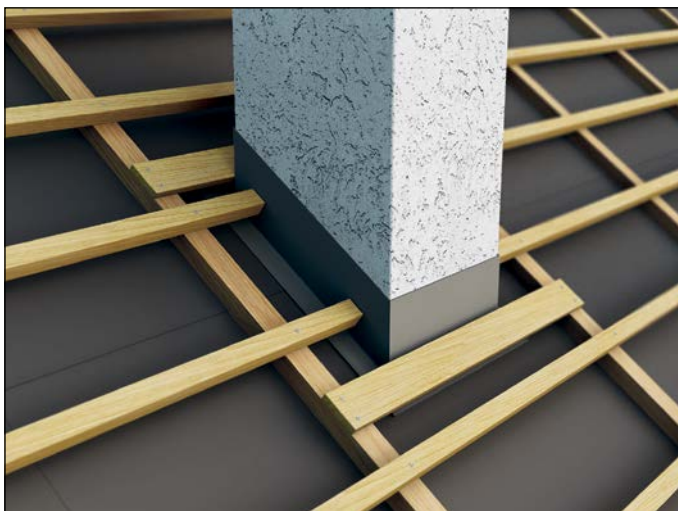

For maximum waterproofing we recommend using an appropriate roofing sealant where the sides of the chimney flashing meet the tiles and also where the chimney flashing connects to the chimney wall.

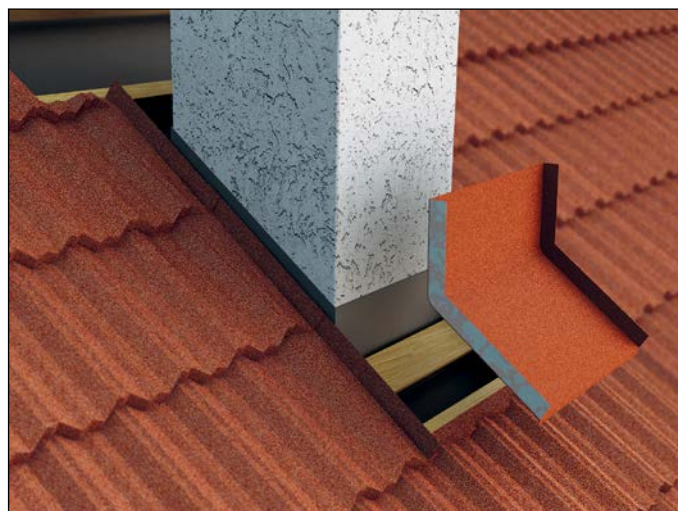

21 CHIMNEY FLASHING

- 1 Tile
- 2 Tile Batten
- 3 Ventilation Space Batten
- 8 Underlay
- 9 Rafter
- 27 Chimney Flashing
- 28 Support Board

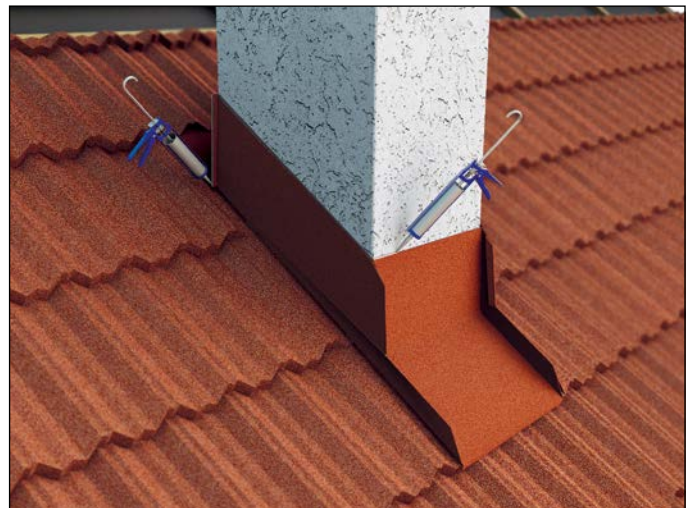
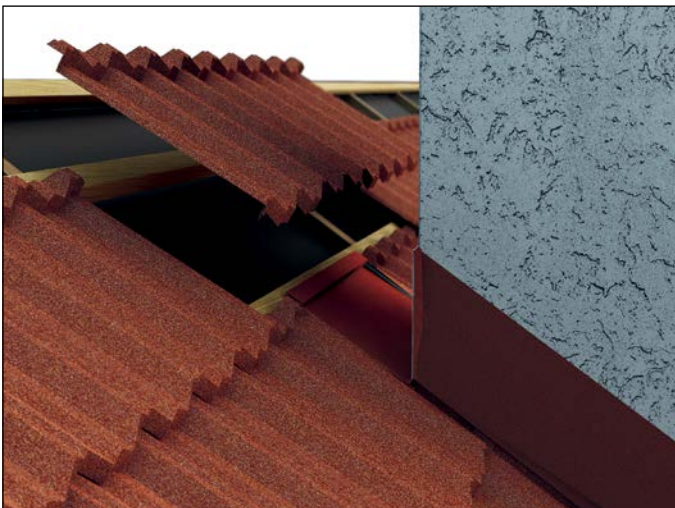
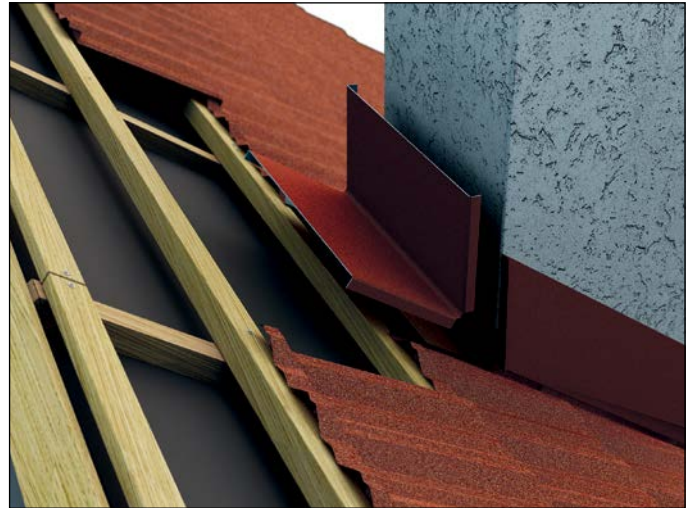
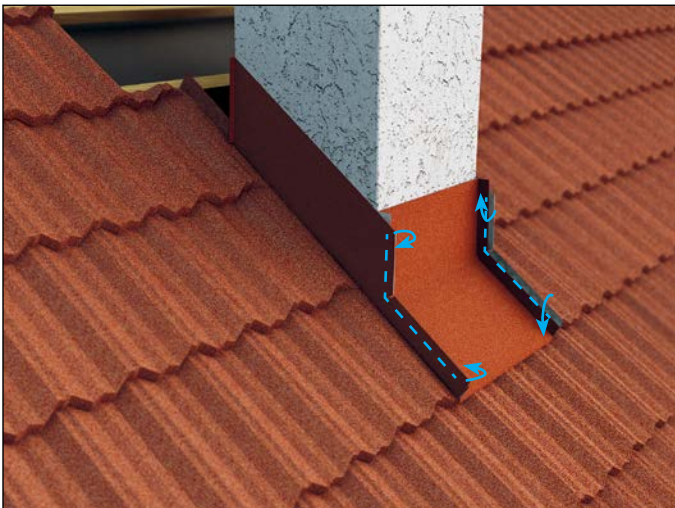
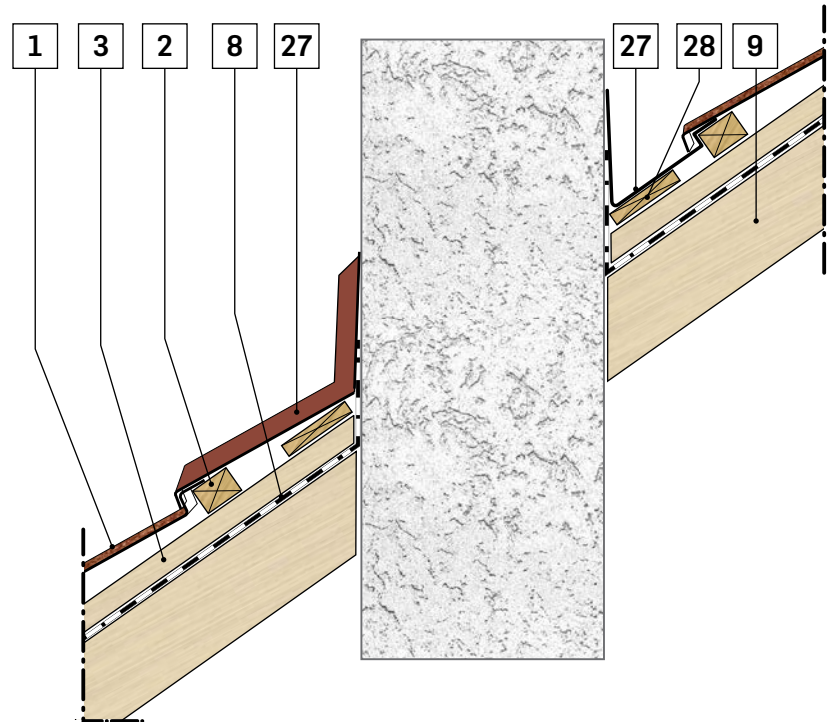

22 ROOF WINDOW

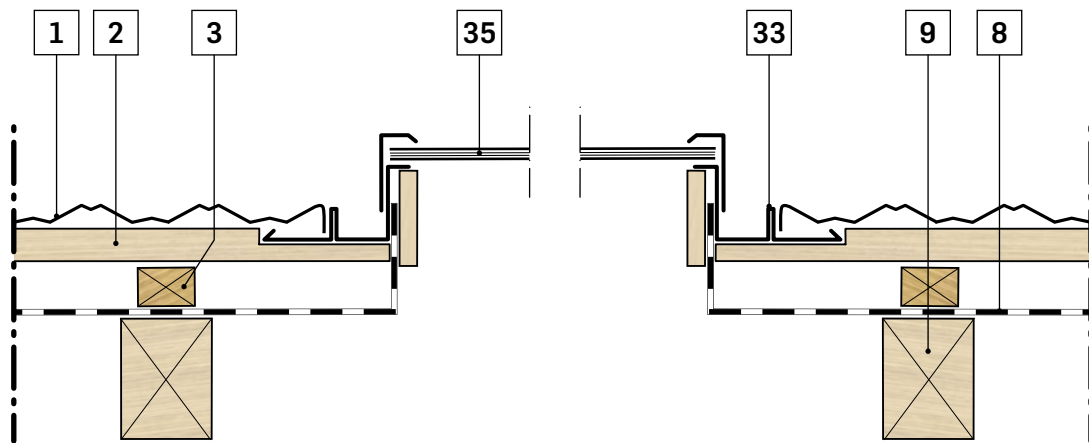

- 1 Tile
- 2 Tile Batten
- 3 Ventilation Space Batten
- 8 Underlay
- 9 Rafter
- 33 Roof Window Flashing
- 35 Roof Window

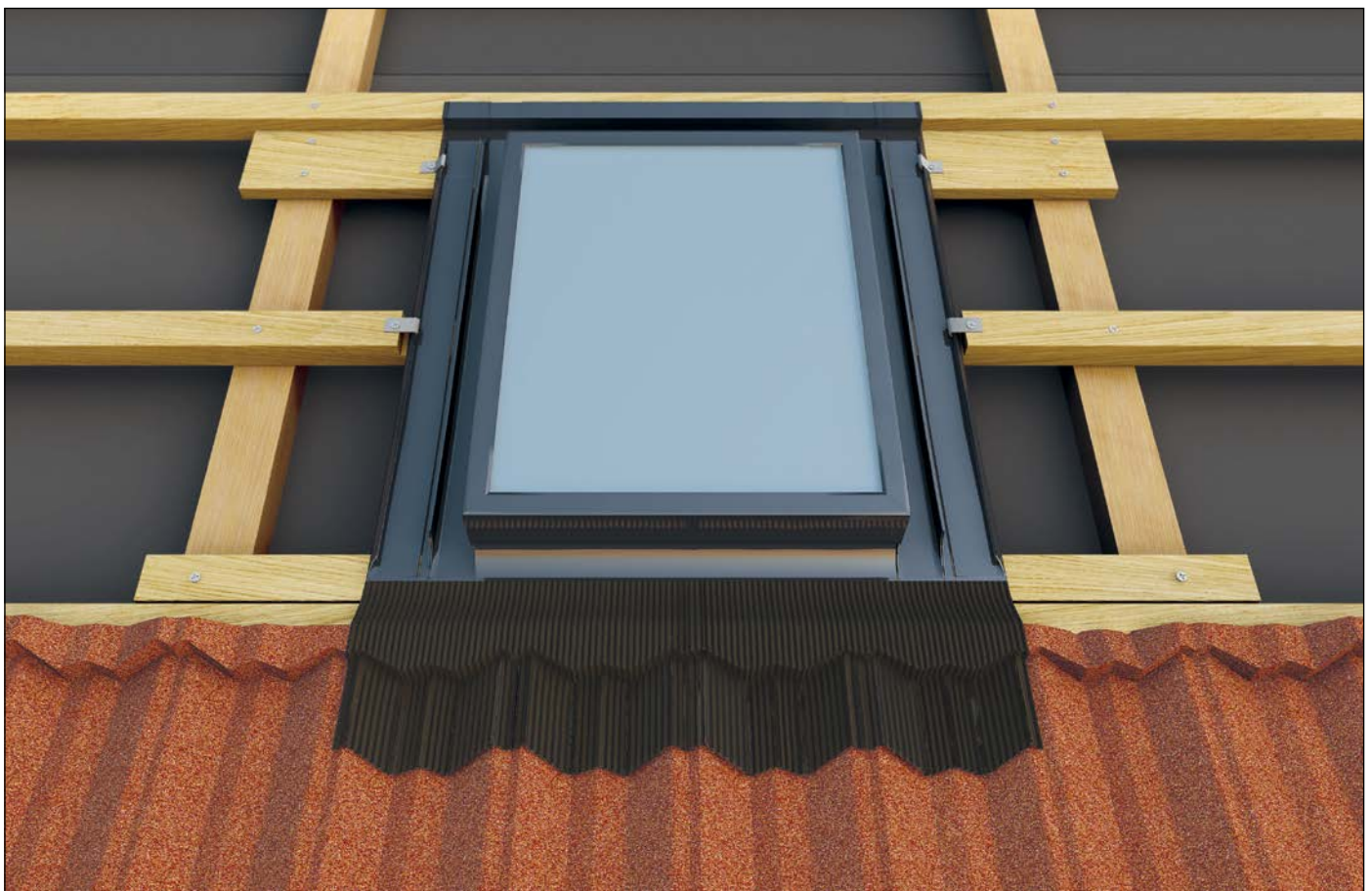

22 ROOF WINDOW

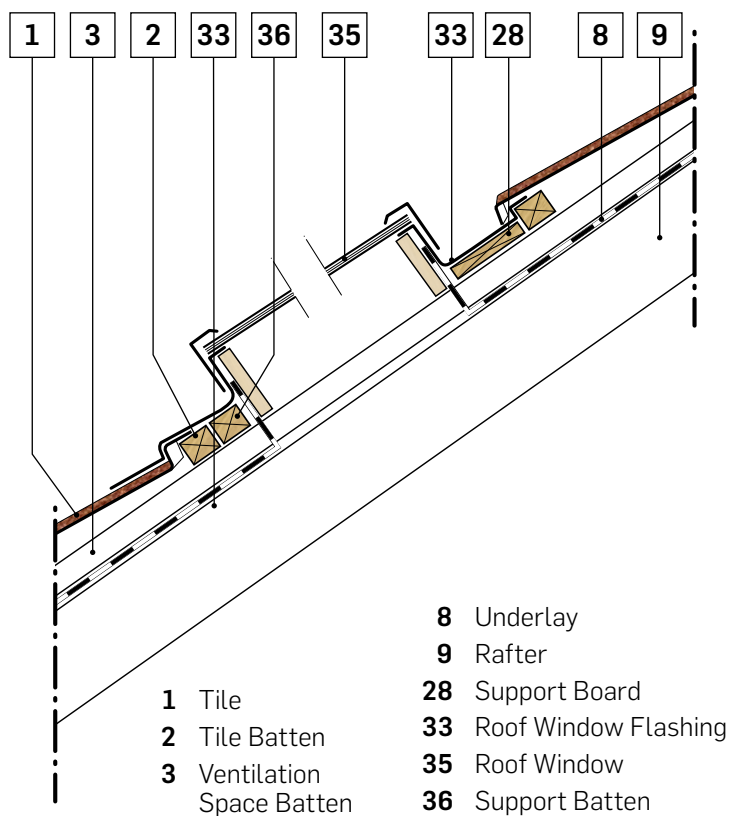

23 INSTALLING ACCESSORIES

VENTS, OUTLETS

Position Vents and outlets below tiles at the sides. Nail them as shown on the drawing. Avoid nailing into plastic.

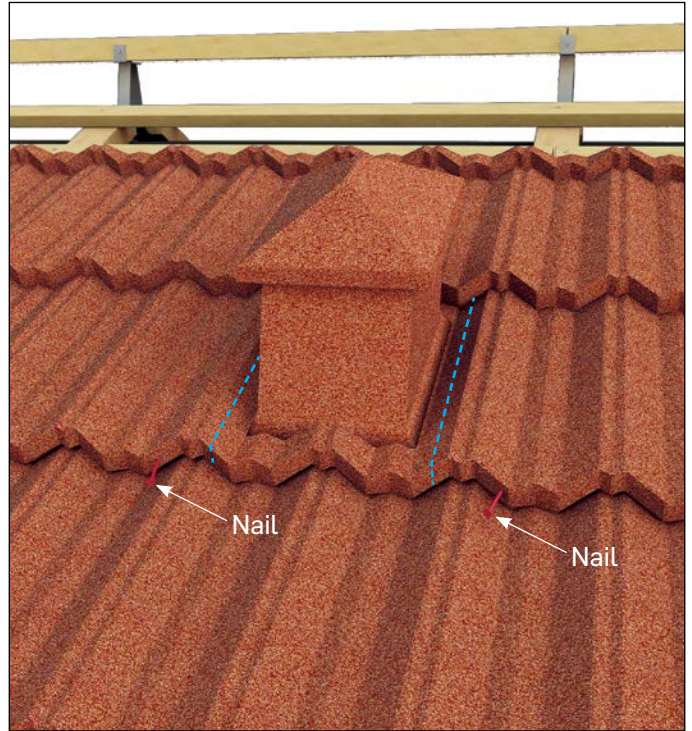
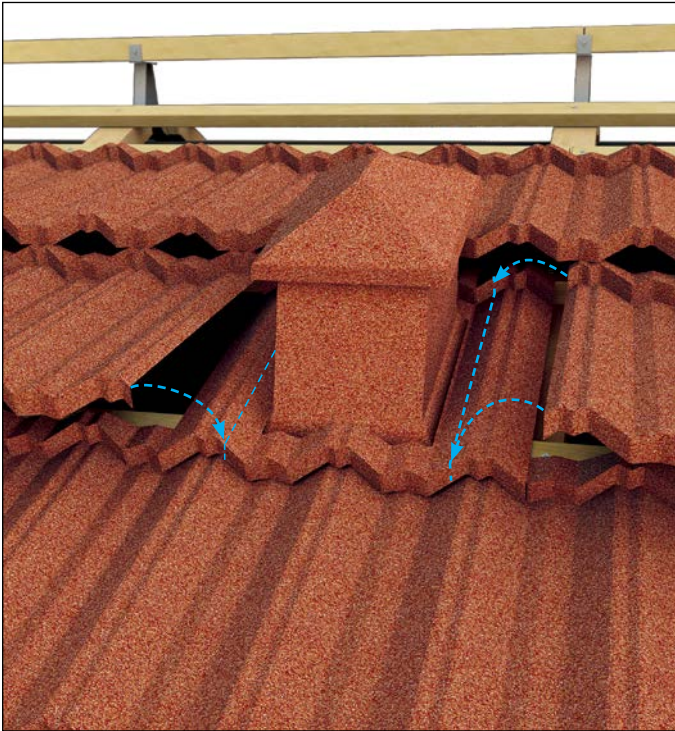

23 INSTALLING ACCESSORIES

PLATFORM, STEPS

Install the base plate first, then drill the holes into the tile and install the tile. Finally install the platform or steps.

For Diamant tile install an additional batten, 3cm width immediately behind the tile batten.

Platform

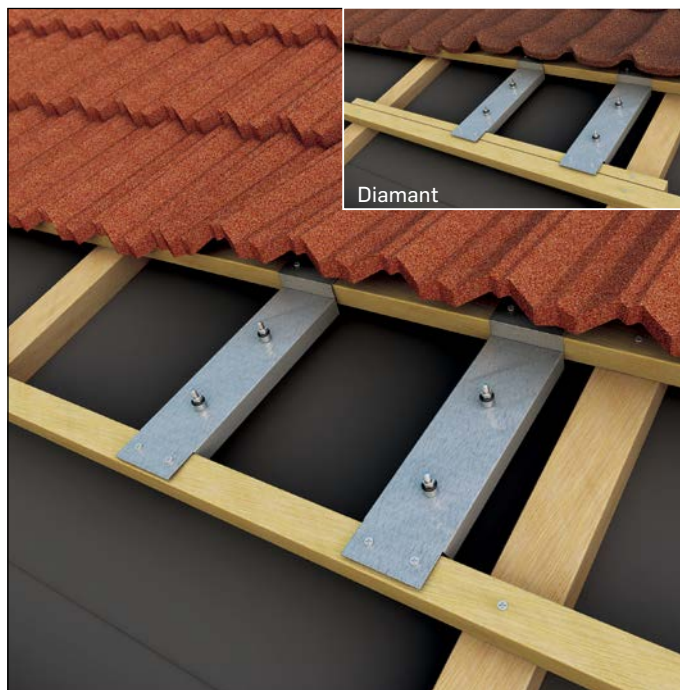

Steps

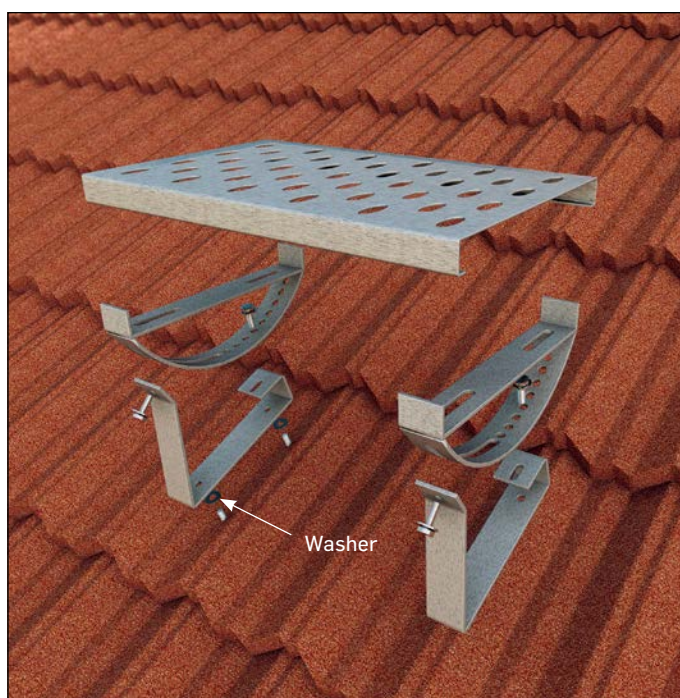
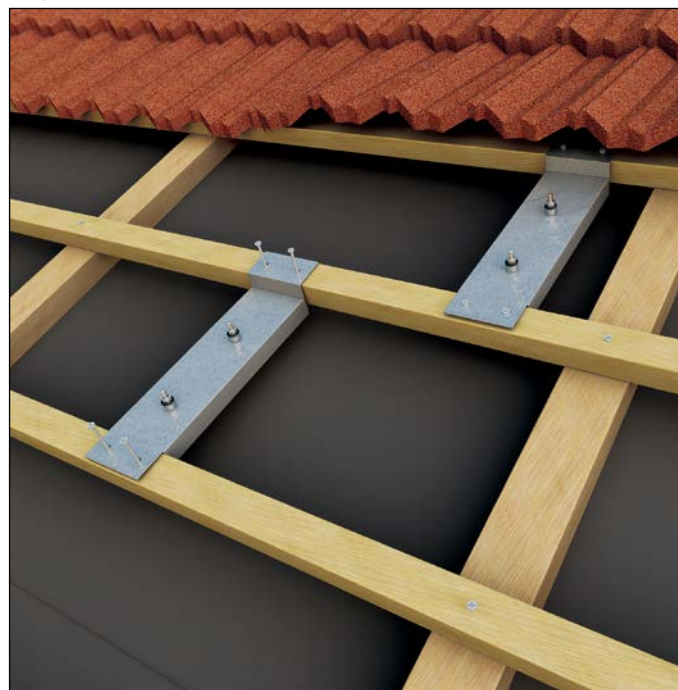

23 INSTALLING ACCESSORIES

SOLAR HOLDER

The size of the rails attached to the roof hooks and carrying the PV module is dependent on local conditions such as snow and wind loads, shape and height of the building, national and local building regulations and standards, and environmental regulations.

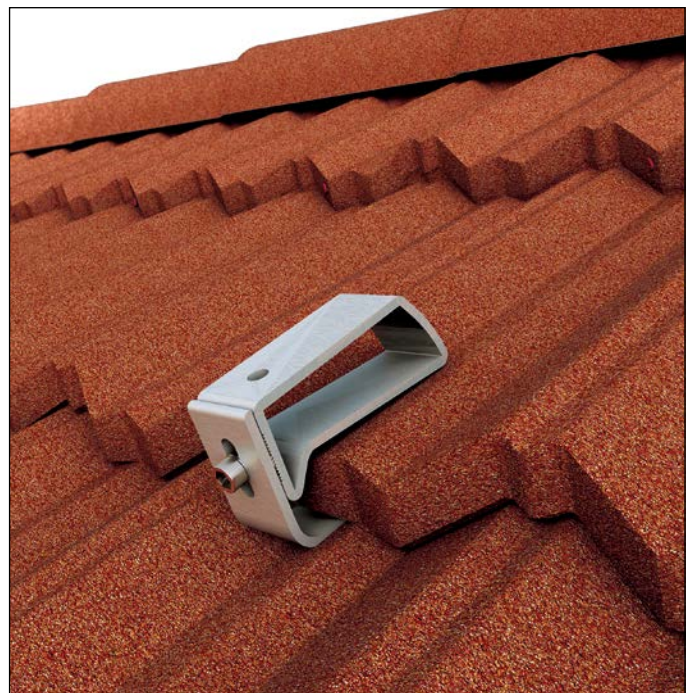
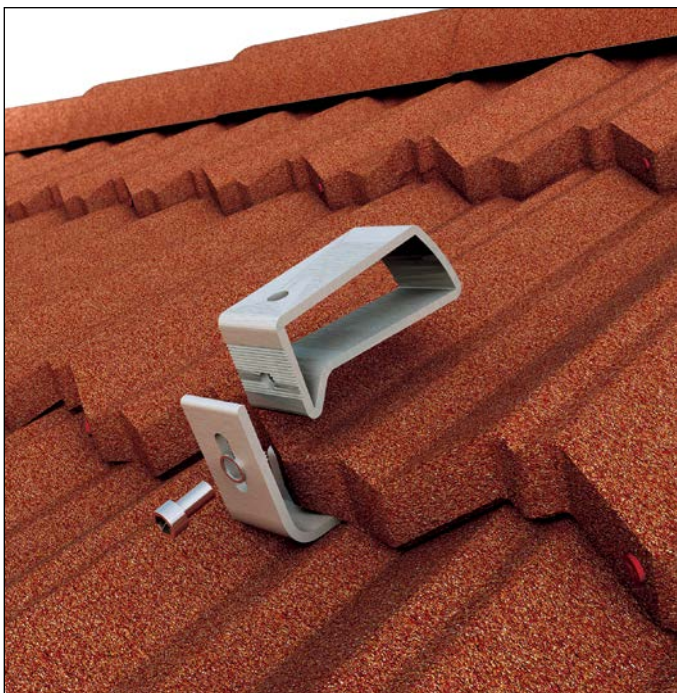
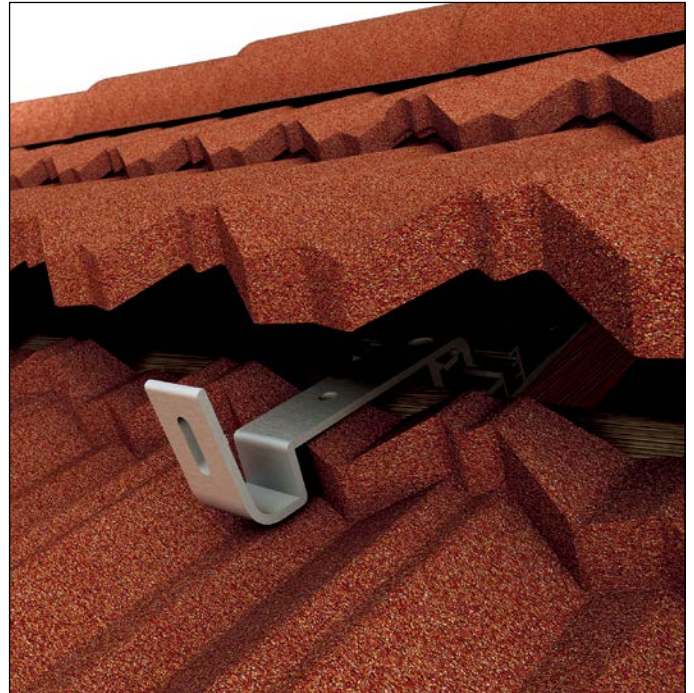

24 MANAGEMENT OF THE WORK SITE

ESTIMATING MATERIALS

The following outlines some simple methods for estimating the quantity of tiles and accessories required for a roof.

IKO Metals Europe can also assist with estimating and provide further technical information or assistance.

Estimating the quantity of tiles required

A simple method for determining the quantity of tiles required is:

1. To calculate Tile, Shake, Shingle and Slate profiles, multiply the surface area of the roof by 2.2. For Milano Tile, multiply by 2.25 and for Diamant Tile multiply by 2.

An example using Gerard Classic Tile:
roof size $578 \text{ m}^2 \times 2.2 \text{ tiles/m}^2 = 1271 \text{ tiles}$.

2. We recommend you build in a wastage factor using the following guidelines.

Add 3-5 % to the quantity for gable roofs.

Add 8-10 % to the quantity for more complex roofs (with valleys or hips).

Estimating the number of accessories required

1. Box Barges: determine the length of the barges. Divide the lineal coverage per accessory (i.e. 1.9 m) to calculate the number of units required.
2. Side Flashings/Flat Sheets: determine the overall length of flashing required. Divide by the lineal coverage per flashing unit (i.e. 1.9 m) to calculate the number of flashing units required.
3. Barrels 205: determine the length of the ridge and hips. Divide the lineal coverage by 0.41 m to calculate the number of Barrels required.

Determining the quantity of nails required

For every 22 m^2 of roof area the following will be required:
1 kg of nails (1 kg is app. 300 nails).

This calculation covers both tile and accessory requirements.

Storing material

Tiles and accessories should be stored in a dry, well-ventilated area, away from damp.

NOTES

NOTES



The worry-proof roof

IKO Metals Europe NV

Michielenweg 3,
3700 Tongeren, Belgium

Phone: +32 12 24 18 01

Email: info.europe@ikometals.com

AUTHORISED PARTNER OF GERARD



is part of

